

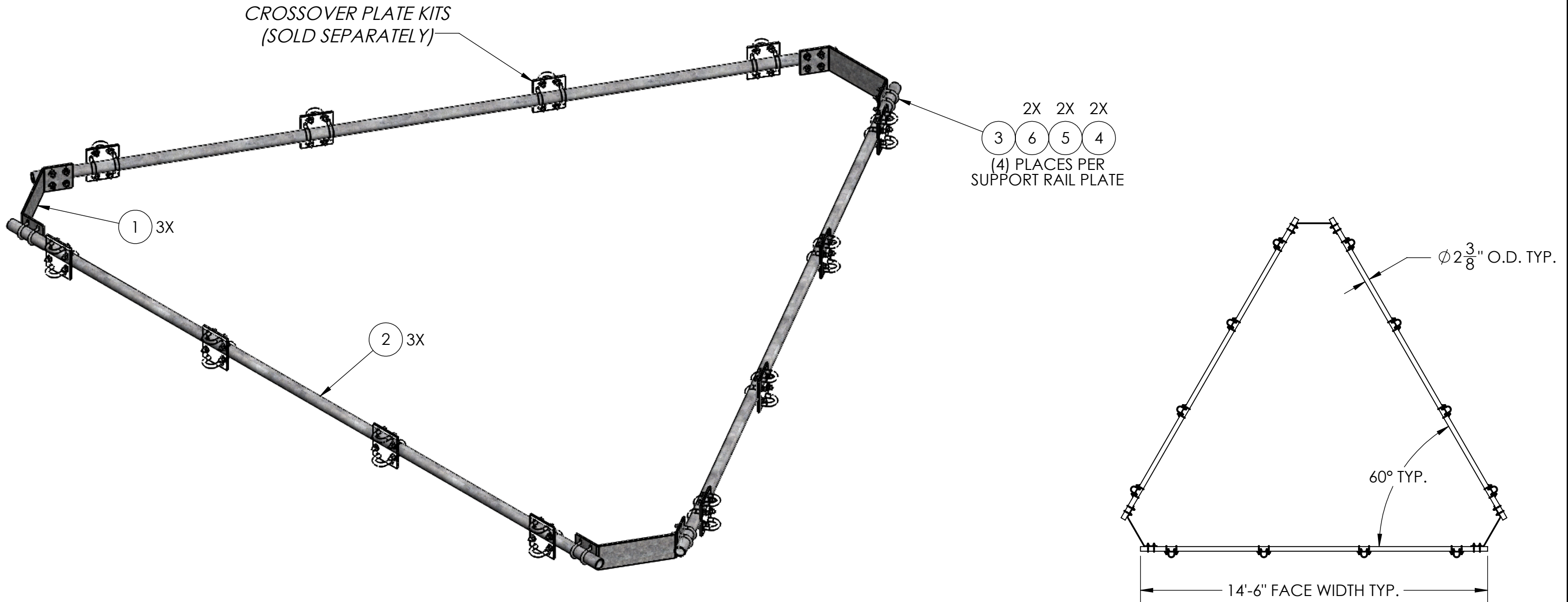

ITEM NO.	PART NUMBER	DESCRIPTION	FINISH	WEIGHT (PER)	QTY.
1	MP1100.01	PLATFORM UPPER SUPPORT RAIL PLATE (3/8" PLATE)	H.D.G.	18.41	3
2	GP2375.174	2-3/8" O.D. x 174" (14'-6") PLAIN END GALV PIPE	H.D.G.	53.16	3
3	GU42440	1/2" x 4" x 2-1/2" x 2" U-BOLT	H.D.G.	0.57	12
4	GF04	1/2" FLAT WASHER	H.D.G.	0.04	24
5	GL04	1/2" LOCK WASHER	H.D.G.	0.02	24
6	GN04A	1/2" HEX NUT (2H)	H.D.G.	0.06	24



UNLESS OTHERWISE SPECIFIED: DIMENSIONS ARE IN INCHES TOLERANCE $\pm 1/16$		DESCRIPTION: 14'-6" PLATFORM UPPER SUPPORT RAIL KIT	
MATERIAL -		 PRO TOWER MANUFACTURING L.L.C. 5601 San Francisco St. NE Albuquerque, N.M. 87109 (505) 924-2810	DWG NO: MP1101
FINISH H.D.G.			DRAWN BY: A.J.K. CHECKED BY: E.FILMER SHEET: 1 of 1
SIZE B PROPRIETARY AND CONFIDENTIAL THE INFORMATION CONTAINED IN THIS DRAWING IS THE SOLE PROPERTY OF PRO TOWER MANUFACTURING L.L.C. ANY REPRODUCTION IN PART OR AS A WHOLE WITHOUT THE WRITTEN PERMISSION OF PRO TOWER MANUFACTURING L.L.C. IS PROHIBITED.		REV WEIGHT: 224.43	