

ITEM NO.	PART NUMBER	DESCRIPTION	FINISH	WEIGHT (PER)	QTY.
1	GU33550	3/8" x 5" x 3-5/8" x 2" U-BOLT	H.D.G.	0.40	1
2	GN03	3/8" HEX NUT	H.D.G.	0.02	2
3	GL03	3/8" LOCK WASHER	H.D.G.	0.01	2
4	GF03	3/8" FLAT WASHER	H.D.G.	0.02	2

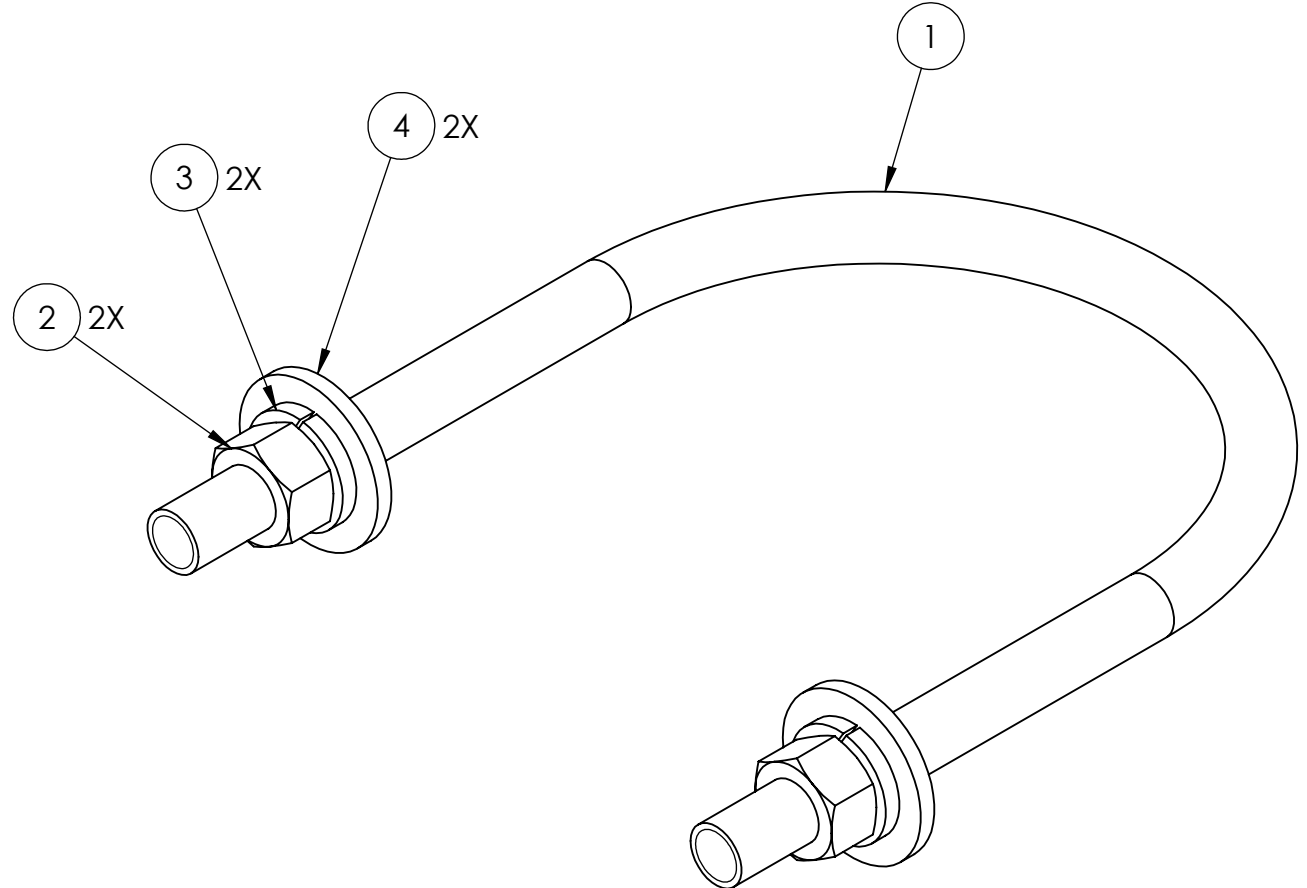
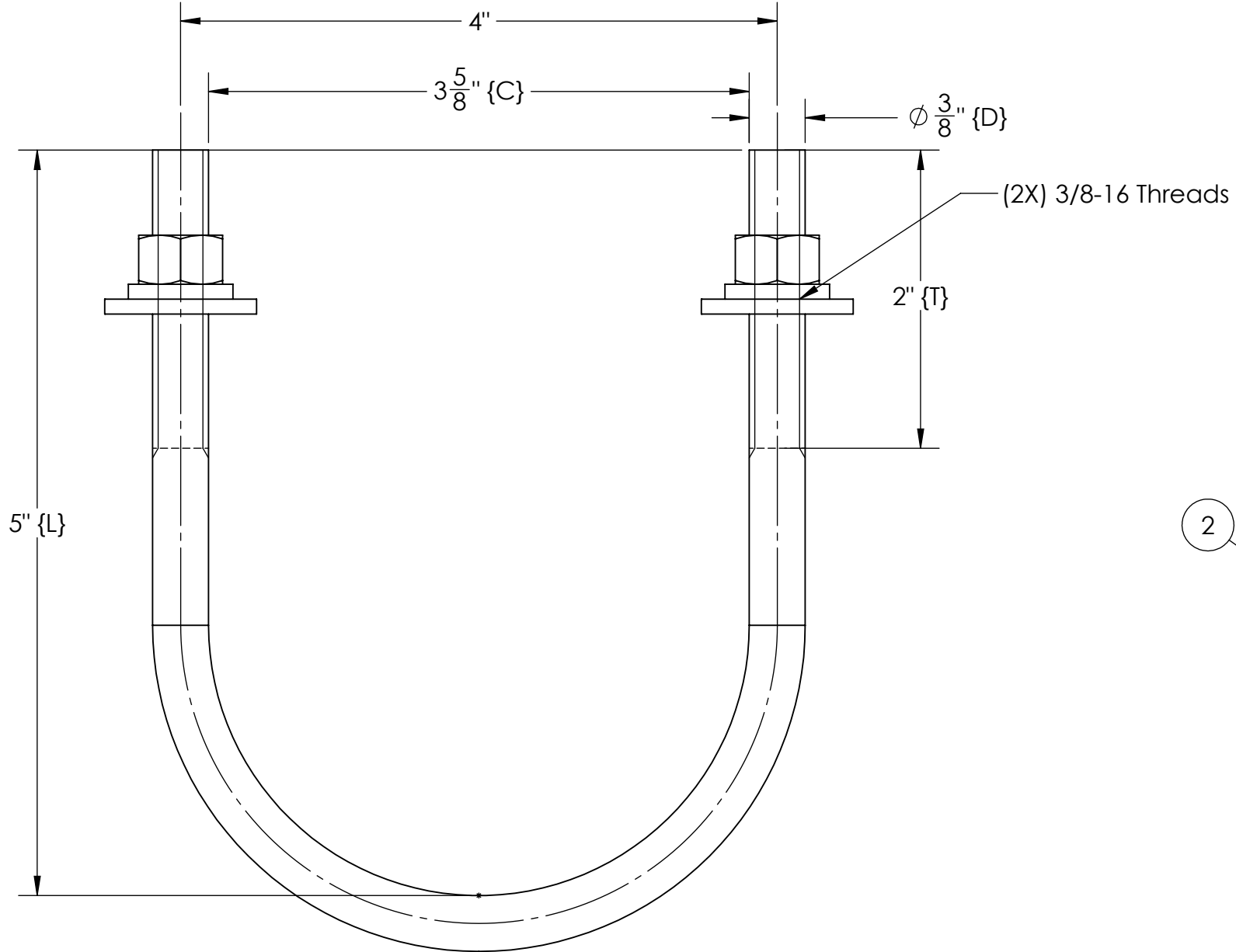

UNLESS OTHERWISE SPECIFIED: DIMENSIONS ARE IN INCHES TOLERANCE ± 1/16		DESCRIPTION: 3/8" x 5" x 3-5/8" x 2" U-BOLT ASSM.		
MATERIAL		 <b>PRO TOWER MANUFACTURING L.L.C.</b> 5601 San Francisco St. NE Albuquerque, N.M. 87109 (505) 924-2810	DWG NO: GUA33550	
FINISH: H.D.G.			DRAWN BY: A.J.K. CHECKED BY: T.SMYTHE SHEET: 1 of 1	DATE: 6/17/2021 DATE: 6/17/2021 SCALE: NTS

SIZE  
**B**

PROPRIETARY AND CONFIDENTIAL  
THE INFORMATION CONTAINED IN THIS  
DRAWING IS THE SOLE PROPERTY OF  
PRO TOWER MANUFACTURING L.L.C. ANY  
REPRODUCTION IN PART OR AS A WHOLE  
WITHOUT THE WRITTEN PERMISSION OF  
PRO TOWER MANUFACTURING L.L.C. IS  
PROHIBITED.