

ITEM NO.	PART NUMBER	DESCRIPTION	FINISH	WEIGHT (PER)	QTY.
1	GU54574	5/8" x 7-1/2" x 4-5/8" x 2-1/2" U-BOLT	H.D.G.	1.62	1
2	GN05A	5/8" HEX NUT	H.D.G.	0.12	2
3	GL05	5/8" LOCK WASHER	H.D.G.	0.03	2
4	GF05	5/8" FLAT WASHER	H.D.G.	0.08	2

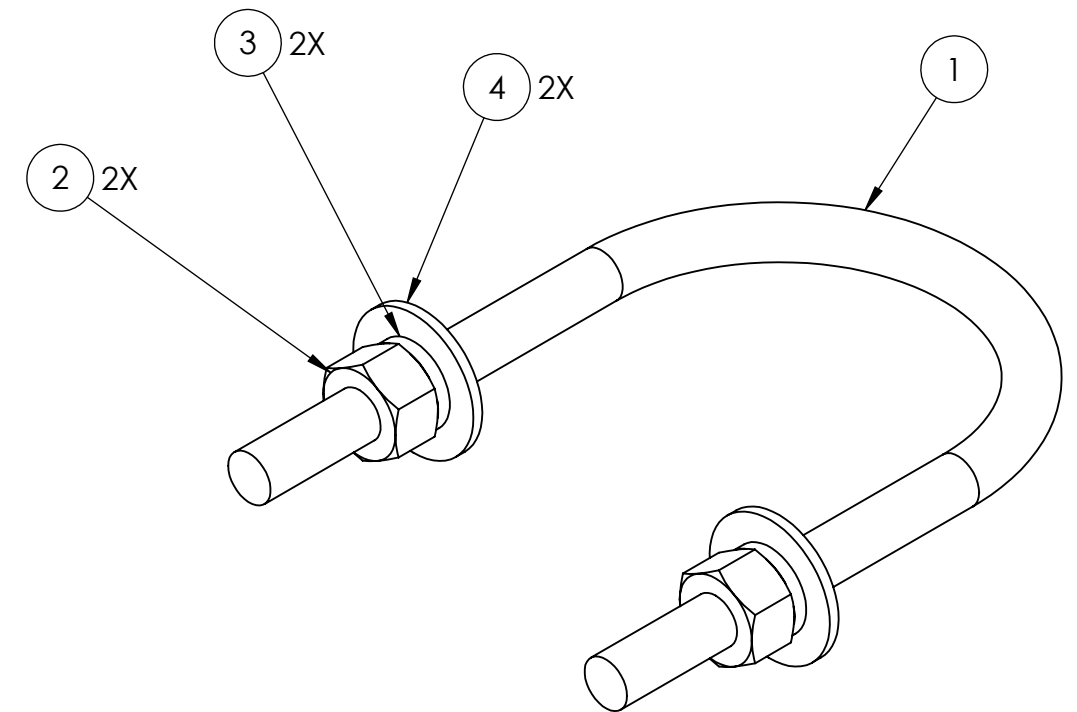
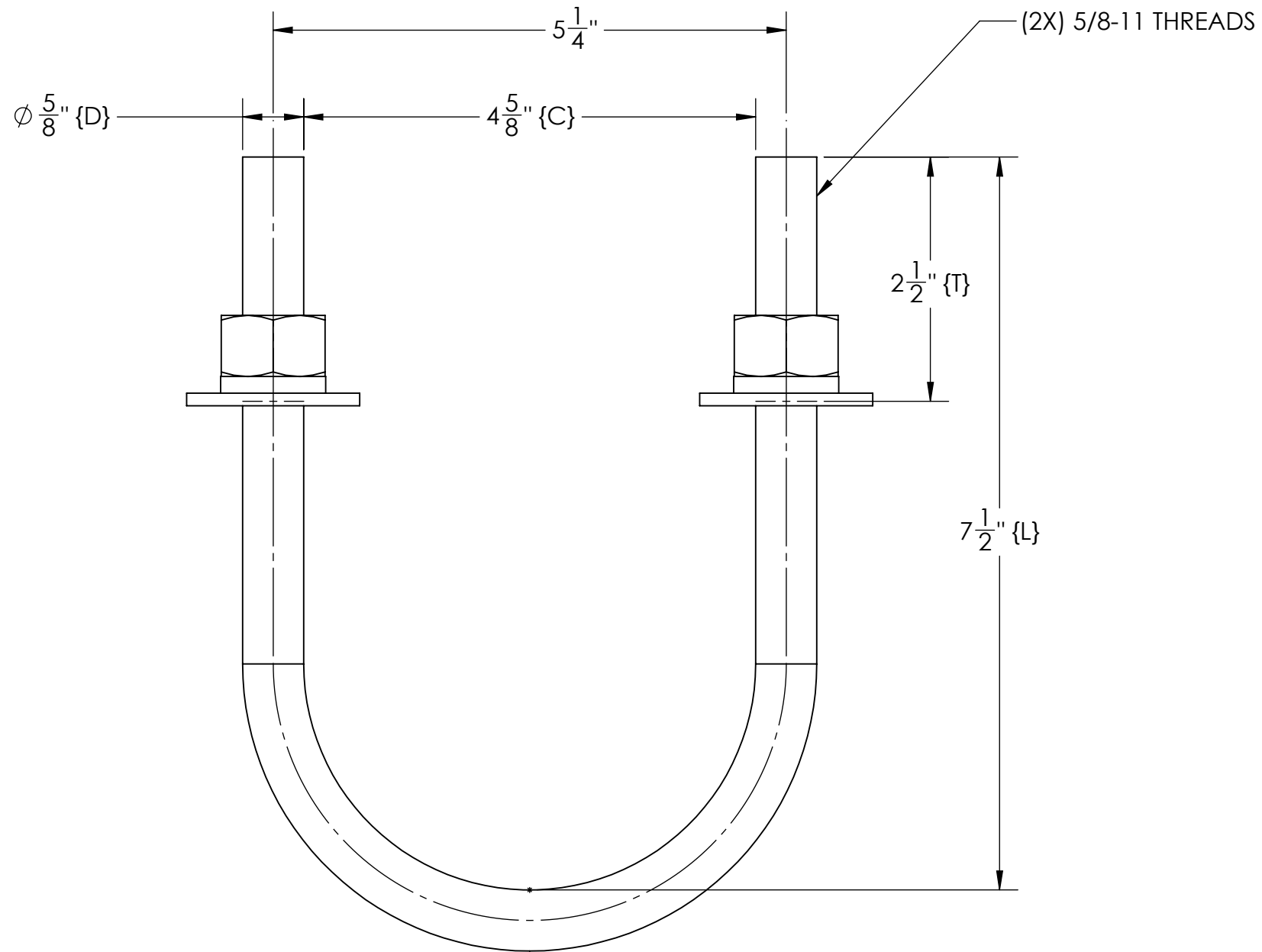

UNLESS OTHERWISE SPECIFIED: DIMENSIONS ARE IN INCHES TOLERANCE $\pm 1/16$		DESCRIPTION: 5/8" x 7-1/2" x 4-5/8" x 2-1/2" U-BOLT ASSM.	
MATERIAL -		 <b>PRO TOWER MANUFACTURING L.L.C.</b> 5601 San Francisco St. NE Albuquerque, N.M. 87109 (505) 924-2810	DWG NO: GUA54574
FINISH H.D.G.	PROPRIETARY AND CONFIDENTIAL THE INFORMATION CONTAINED IN THIS DRAWING IS THE SOLE PROPERTY OF PRO TOWER MANUFACTURING L.L.C. ANY REPRODUCTION IN PART OR AS A WHOLE WITHOUT THE WRITTEN PERMISSION OF PRO TOWER MANUFACTURING L.L.C. IS PROHIBITED.		DRAWN BY: A.J.K. CHECKED BY: T.SMYTHE SHEET: 1 of 1
SIZE <b>B</b>		REV: 2.07	