

COMPONENTS FOR PART NUMBER IS-RH KIT (ORDER SEPARATELY)	
DESCRIPTION	QTY.
5/8" x 1.5 TON PIN SHACKLE	5
7/16" HEAVY THIMBLE	10
3/8" DROP FORGED WIRE ROPE CLIP	20
3/8" GALV. AIRCRAFT CABLE	100ff
5/8" x 12" J/J TURNBUCKLE	5

ITEM NO.	PART NUMBER	DESCRIPTION	FINISH	WEIGHT (PER)	QTY.
1	IS-F4.01	UNIVERSAL CENTER TRAY (WELDMENT)	H.D.G.	128.10	1
2	IS-F8.02R	RIGHT WING 8FT (WELDMENT)	H.D.G.	127.12	1
3	IS-F8.02L	LEFT WING 8FT (WELDMENT)	H.D.G.	127.12	1
4	IS-F8.04	HORIZONTAL PIPE SUPPORT 8FT (WELDMENT)	H.D.G.	90.59	1
5	GU43550	1/2" x 5-1/2" x 3-5/8" x 2-1/2" U-BOLT	H.D.G.	0.77	4
6	GF04	1/2" FLAT WASHER	H.D.G.	0.04	8
7	GL04	1/2" LOCK WASHER	H.D.G.	0.02	8
8	GN04A	1/2" HEX NUT (2H)	H.D.G.	0.06	8
9	GB0516A	5/8" x 1-3/4" HEX BOLT	H.D.G.	0.26	8
10	GL05	5/8" LOCK WASHER	H.D.G.	0.03	12
11	GN05A	5/8" HEX NUT (2H)	H.D.G.	0.12	12
12	GU54564	5/8" x 6-1/2" x 4-5/8" x 3" U-BOLT	H.D.G.	1.45	2
13	GF05	5/8" FLAT WASHER	H.D.G.	0.08	4

AIRCRAFT CABLE W/ CABLE HARDWARE SHOWN FOR ASSEMBLY CLARITY ONLY (ORDER SEPARATELY)

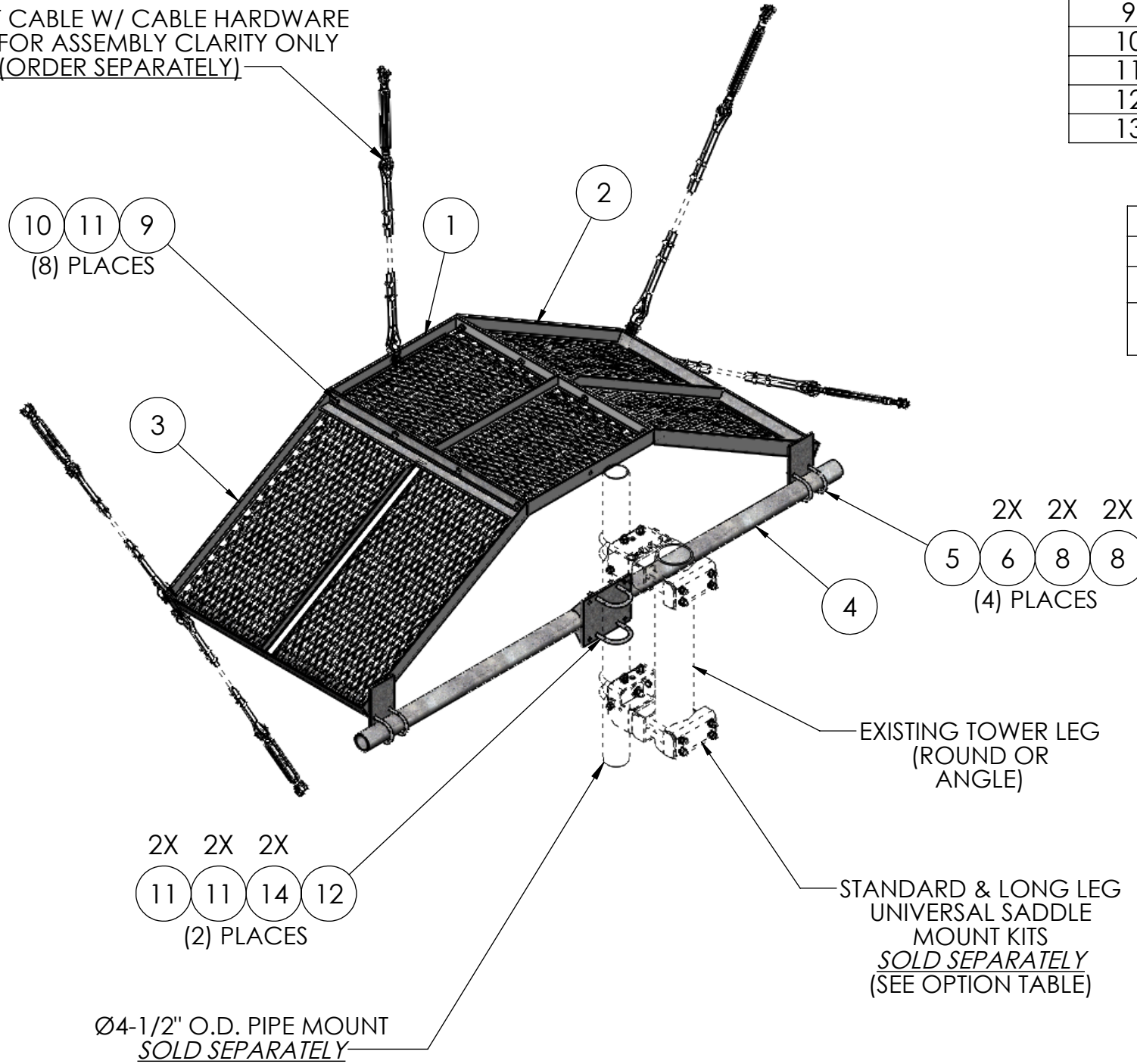

SOLD SEPARATELY			
PART NUMBER	DESCRIPTION	FITS (ANGLE & PIPE TOWER LEGS)	QTY.
TW1126	UNIVERSAL SADDLE MOUNT	L2-3/4" TO L4-1/2" / Ø1-3/4" TO Ø6-5/8" O.D.	1
TW1128	UNIVERSAL SADDLE MOUNT (LONG LEG ADAPTER KIT)	L3" TO L8-1/2" / Ø1-3/4" TO Ø12" O.D.	1

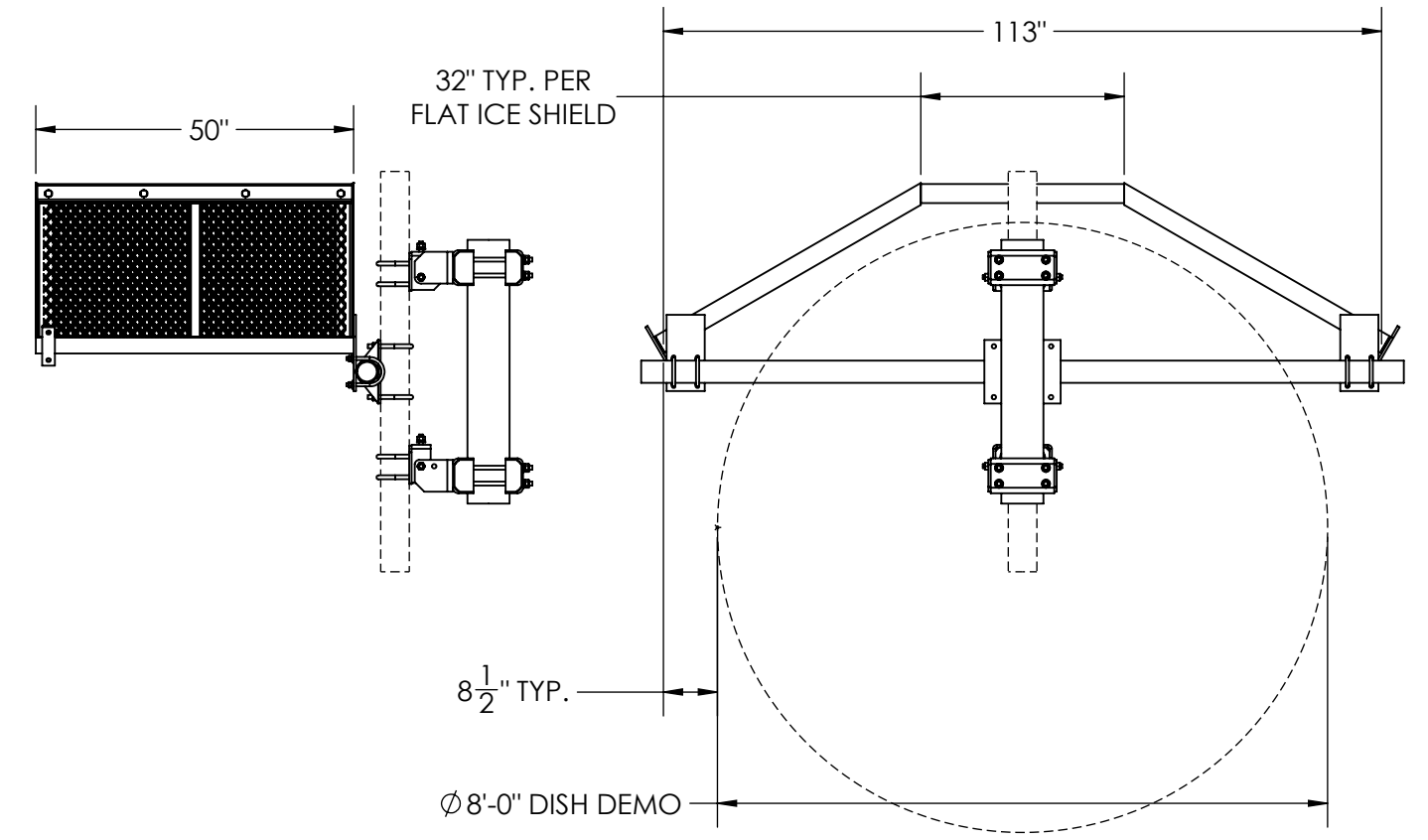

MATERIAL -	FINISH H.D.G.	SIZE B	UNLESS OTHERWISE SPECIFIED: DIMENSIONS ARE IN INCHES TOLERANCE ± 1/16	DESCRIPTION: 8'-0" FLAT ICE SHIELD, FITS 7' - 8' DISH	DWG NO: IS-F8
			PROPRIETARY AND CONFIDENTIAL THE INFORMATION CONTAINED IN THIS DRAWING IS THE SOLE PROPERTY OF PRO TOWER MANUFACTURING L.L.C. ANY REPRODUCTION IN PART OR AS A WHOLE WITHOUT THE WRITTEN PERMISSION OF PRO TOWER MANUFACTURING L.L.C. IS PROHIBITED.	 PRO TOWER MANUFACTURING L.L.C. 5601 San Francisco St. NE Albuquerque, N.M. 87109 (505) 924-2810	DRAWN BY: AJK CHECKED BY: E. FILMER SHEET: 1 of 1