

ITEM NO.	PART NUMBER	DESCRIPTION	FINISH	WEIGHT (PER)	QTY.
1	TW1159.01	HEAVY DUTY CROSSOVER PLATE, 5/8" HARDWARE	H.D.G.	6.67	1
2	GU54445	5/8" x 4-1/2" x 3" x 2" U-BOLT	H.D.G.	1.02	4
3	GF05	5/8" FLAT WASHER	H.D.G.	0.08	8
4	GL05	5/8" LOCK WASHER	H.D.G.	0.03	8
5	GN05A	5/8" HEX NUT(2H)	H.D.G.	0.12	8

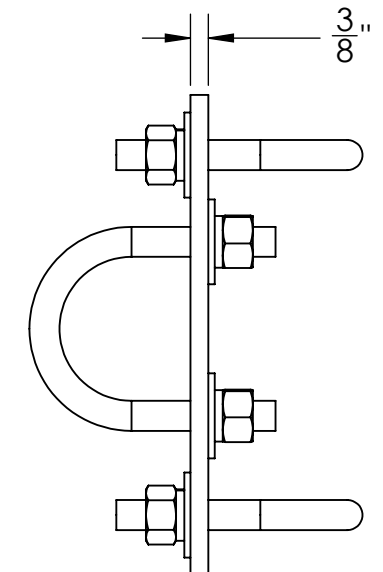
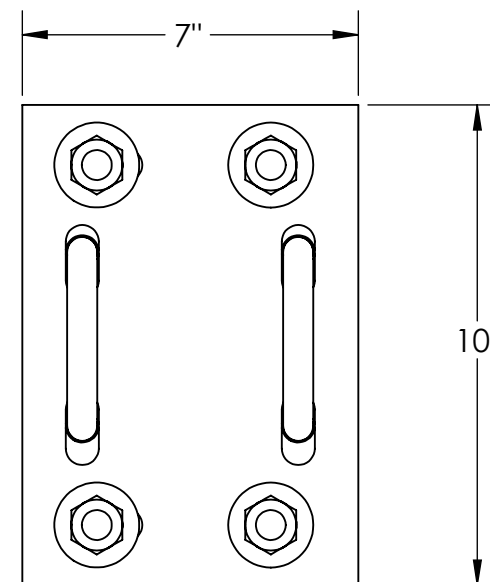
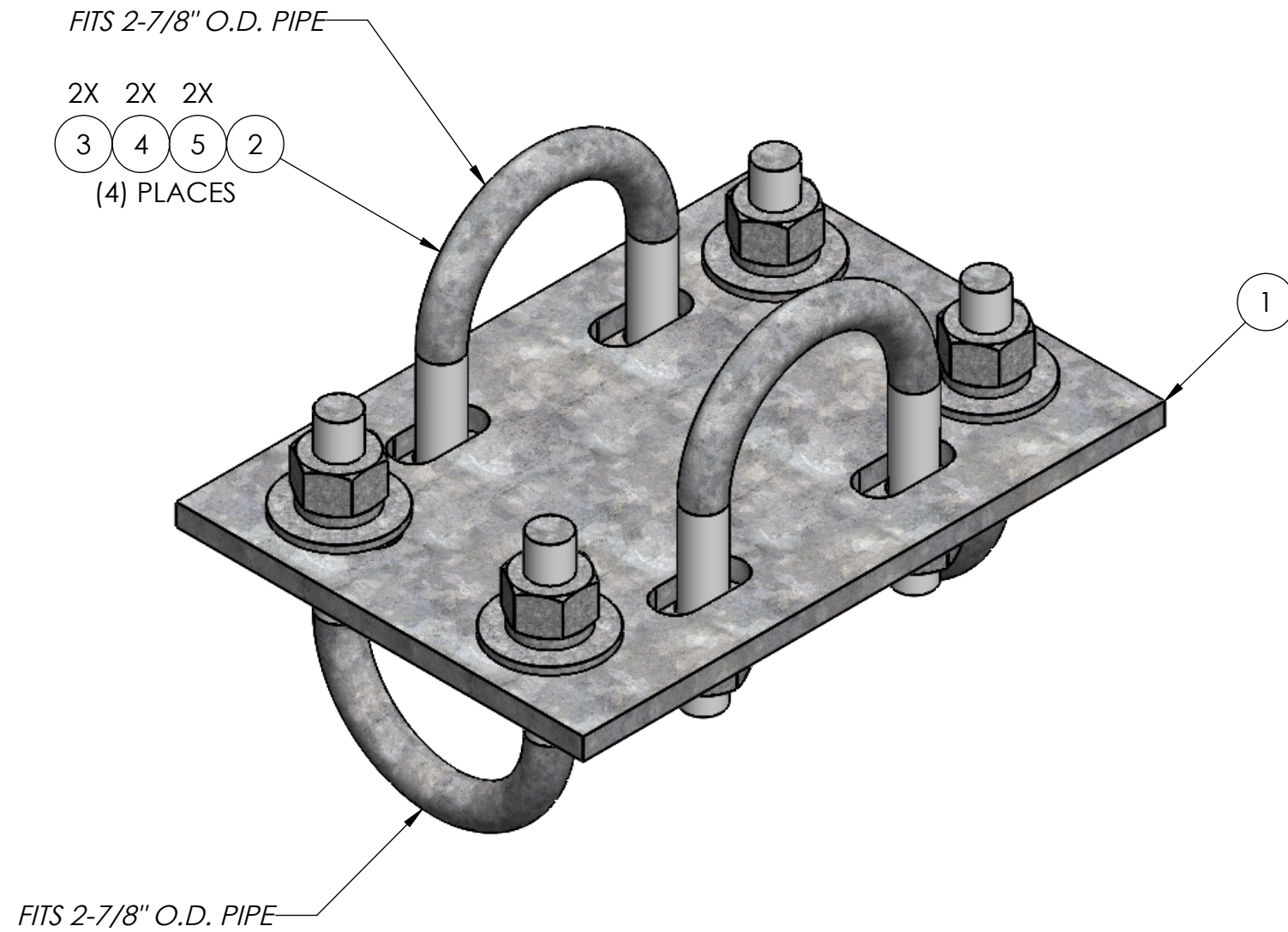

UNLESS OTHERWISE SPECIFIED: DIMENSIONS ARE IN INCHES TOLERANCE ± 1/16		DESCRIPTION: HEAVY DUTY CROSSOVER PLATE KIT, 2-7/8" O.D. TO 2-7/8" O.D. PIPE	
MATERIAL -		 PRO TOWER MANUFACTURING L.L.C. 5601 San Francisco St. NE Albuquerque, N.M. 87109 (505) 924-2810	DWG NO: TW1162
FINISH H.D.G.	SIZE B		DRAWN BY: A.J.K. CHECKED BY: T.SMYTHE SHEET: 1 of 1
PROPRIETARY AND CONFIDENTIAL THE INFORMATION CONTAINED IN THIS DRAWING IS THE SOLE PROPERTY OF PRO TOWER MANUFACTURING L.L.C. ANY REPRODUCTION IN PART OR AS A WHOLE WITHOUT THE WRITTEN PERMISSION OF PRO TOWER MANUFACTURING L.L.C. IS PROHIBITED.		DATE: 6/30/2021	REV
		DATE: 6/30/2021	WEIGHT: 12.54
		SCALE: NTS	