

ITEM NO.	PART NUMBER	DESCRIPTION	FINISH	WEIGHT (PER)	QTY.
1	TW1107	LARGE CROSSOVER PLATE (3/8" PLATE)	H.D.G.	8.22	1
2	GU43550	1/2" x 5-1/2" x 3-5/8" x 2-1/2" U-BOLT	H.D.G.	0.77	2
3	GF04	1/2" FLAT WASHER	H.D.G.	0.04	4
4	GL04	1/2" LOCK WASHER	H.D.G.	0.02	4
5	GN04A	1/2" HEX NUT	H.D.G.	0.06	4
6	GU54564	5/8" x 6-1/2" x 4-5/8" x 3" U-BOLT	H.D.G.	1.45	2
7	GF05	5/8" FLAT WASHER	H.D.G.	0.08	4
8	GL05	5/8" LOCK WASHER	H.D.G.	0.03	4
9	GN05A	5/8" HEX NUT	H.D.G.	0.12	4

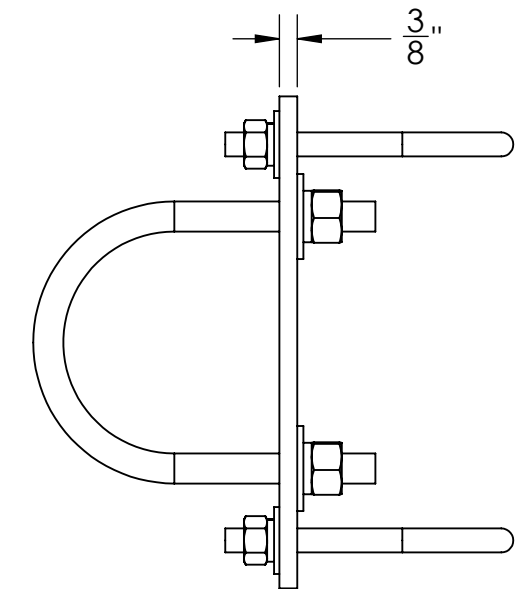
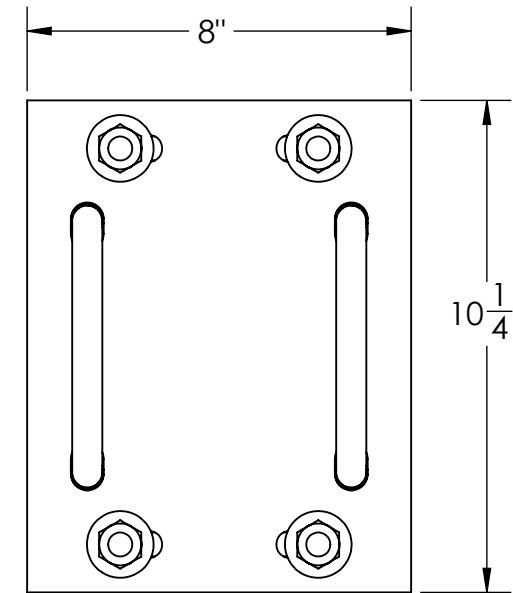
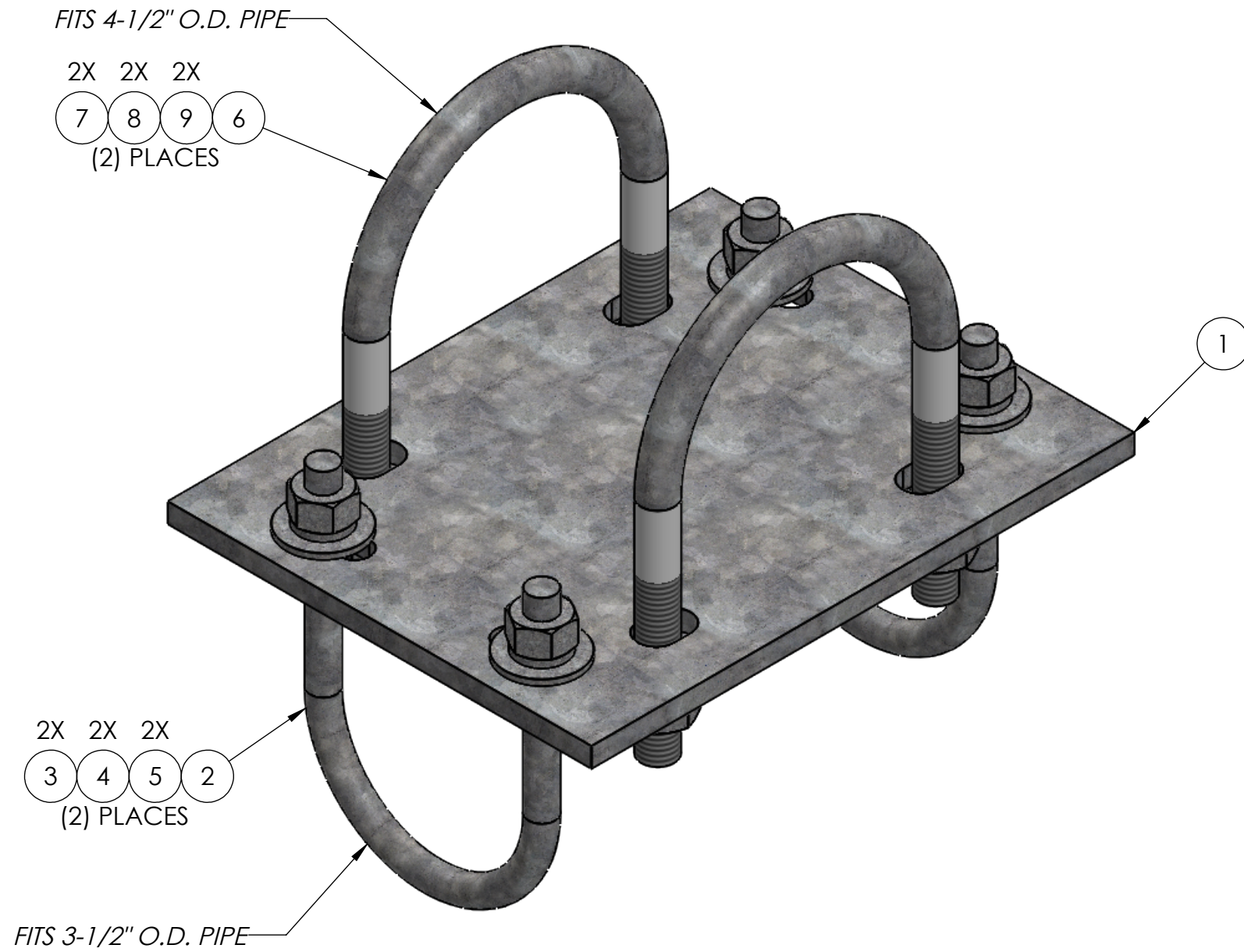

MATERIAL -	FINISH H.D.G.	SIZE B	UNLESS OTHERWISE SPECIFIED: DIMENSIONS ARE IN INCHES TOLERANCE ± 1/16	DESCRIPTION: LARGE CROSSOVER PLATE KIT, 3-1/2" O.D. TO 4-1/2" O.D. PIPE	DWG NO: TW1110
			PROPRIETARY AND CONFIDENTIAL THE INFORMATION CONTAINED IN THIS DRAWING IS THE SOLE PROPERTY OF PRO TOWER MANUFACTURING L.L.C. ANY REPRODUCTION IN PART OR AS A WHOLE WITHOUT THE WRITTEN PERMISSION OF PRO TOWER MANUFACTURING L.L.C. IS PROHIBITED.	 PRO TOWER MANUFACTURING L.L.C. 5601 San Francisco St. NE Albuquerque, N.M. 87109 (505) 924-2810	DRAWN BY: A.J.K. CHECKED BY: E.FILMER SHEET: 1 of 1