

ITEM NO.	PART NUMBER	DESCRIPTION	FINISH	WEIGHT (PER)	QTY.
1	TW1100	MEDIUM CROSSOVER PLATE (3/8" PLATE)	H.D.G.	5.43	1
2	GU42440	1/2" x 4" x 2-1/2" x 2" U-BOLT	H.D.G.	0.57	4
3	GF04	1/2" FLAT WASHER	H.D.G.	0.04	8
4	GL04	1/2" LOCK WASHER	H.D.G.	0.02	8
5	GN04A	1/2" HEX NUT	H.D.G.	0.06	8

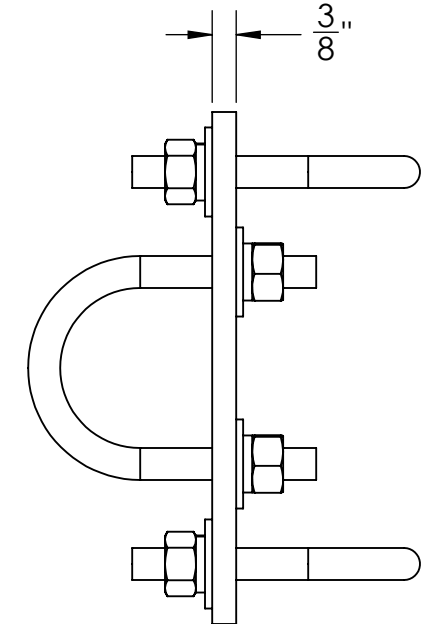
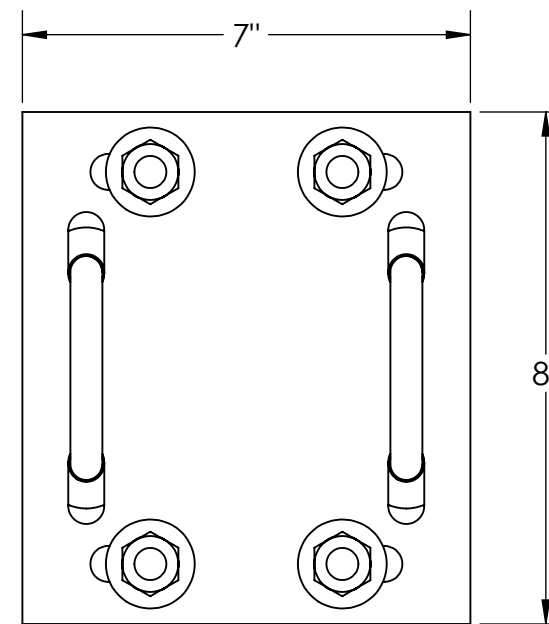
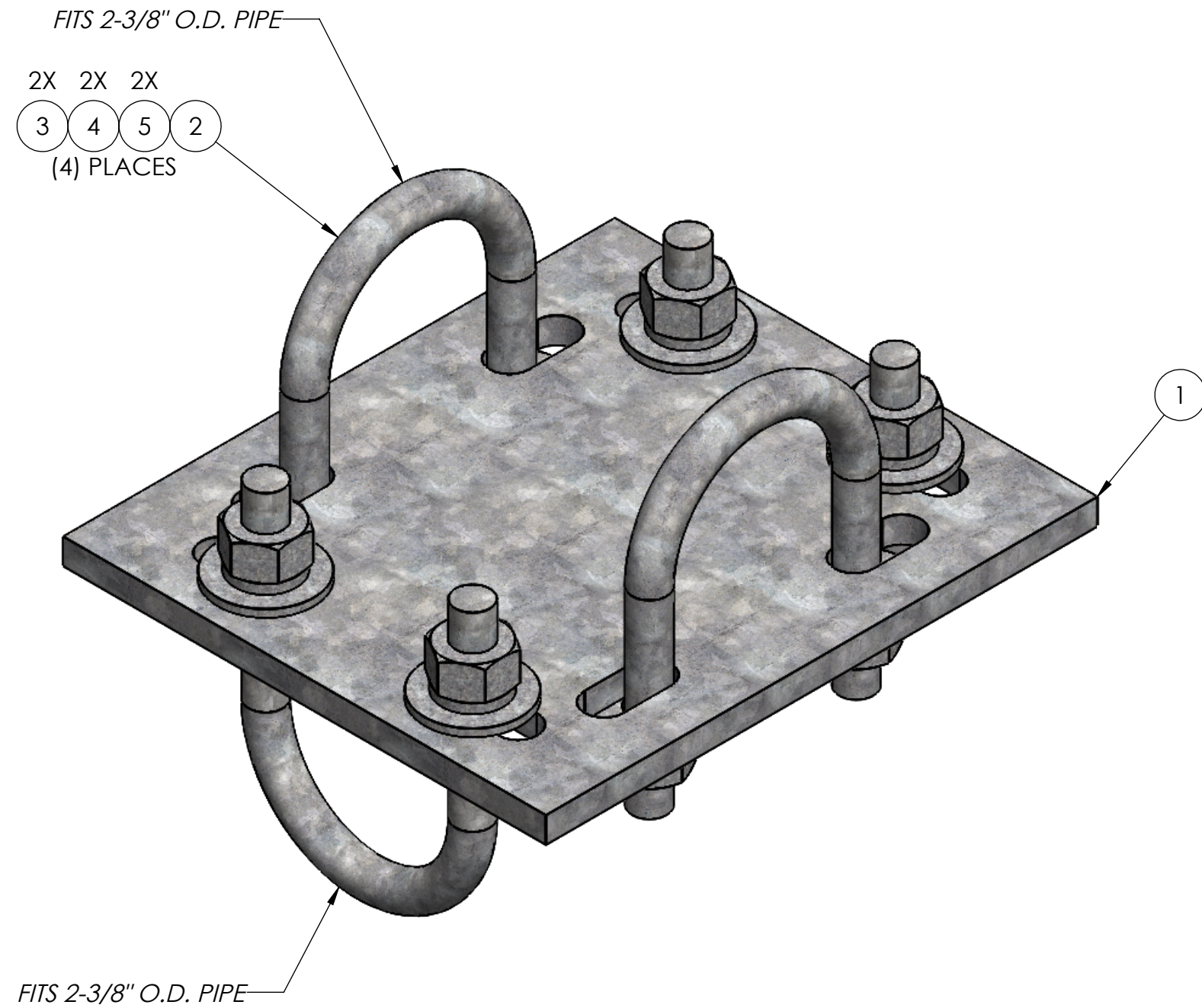

UNLESS OTHERWISE SPECIFIED: DIMENSIONS ARE IN INCHES TOLERANCE ± 1/16		DESCRIPTION: MEDIUM CROSSOVER PLATE KIT, 2-3/8" TO 2-3/8" PIPE	
PROPRIETARY AND CONFIDENTIAL THE INFORMATION CONTAINED IN THIS DRAWING IS THE SOLE PROPERTY OF PRO TOWER MANUFACTURING L.L.C. ANY REPRODUCTION IN PART OR AS A WHOLE WITHOUT THE WRITTEN PERMISSION OF PRO TOWER MANUFACTURING L.L.C. IS PROHIBITED.		 PRO TOWER MANUFACTURING L.L.C. 5601 San Francisco St. NE Albuquerque, N.M. 87109 (505) 924-2810	DWG NO: TW1101
MATERIAL -	FINISH H.D.G.		DRAWN BY: A.J.K. CHECKED BY: E.FILMER SHEET: 1 of 1
SIZE B		REV WEIGHT: 8.67	