

ITEM NO.	PART NUMBER	DESCRIPTION	FINISH	WEIGHT (PER)	QTY.
1	TW1100	MEDIUM CROSSOVER PLATE (3/8" PLATE)	H.D.G.	5.43	1
2	GU43045	1/2" x 4-1/2" x 3" x 2" U-BOLT	H.D.G.	0.64	2
3	GF04	1/2" FLAT WASHER	H.D.G.	0.04	8
4	GL04	1/2" LOCK WASHER	H.D.G.	0.02	8
5	GN04A	1/2" HEX NUT	H.D.G.	0.06	8
6	GU42440	1/2" x 4" x 2-1/2" x 2" U-BOLT	H.D.G.	0.57	2

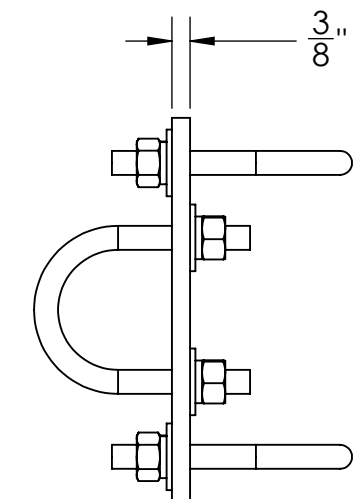
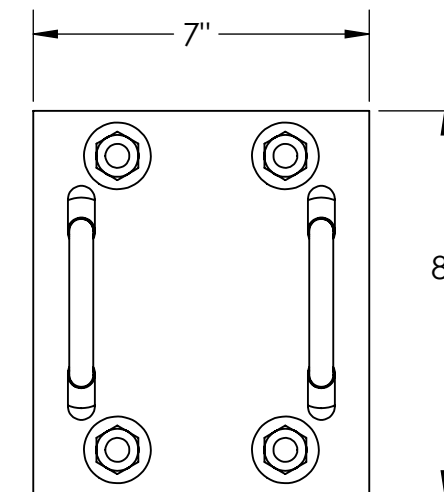
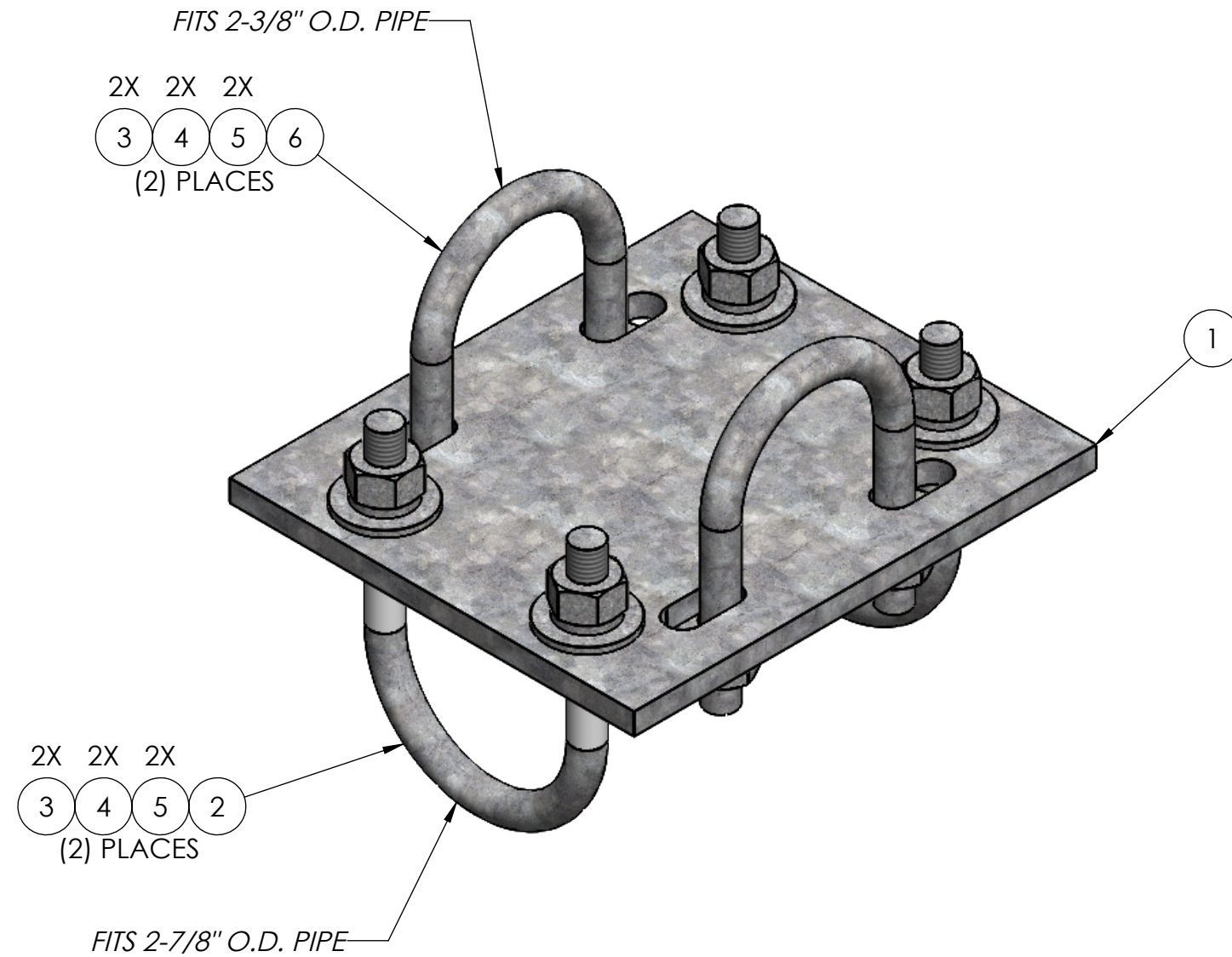

MATERIAL		UNLESS OTHERWISE SPECIFIED: DIMENSIONS ARE IN INCHES TOLERANCE ± 1/16		DESCRIPTION: MEDIUM CROSSOVER PLATE KIT, 2-3/8" TO 2-7/8" PIPE	
FINISH		PROPRIETARY AND CONFIDENTIAL THE INFORMATION CONTAINED IN THIS DRAWING IS THE SOLE PROPERTY OF PRO TOWER MANUFACTURING L.L.C. ANY REPRODUCTION IN PART OR AS A WHOLE WITHOUT THE WRITTEN PERMISSION OF PRO TOWER MANUFACTURING L.L.C. IS PROHIBITED.		 PRO TOWER MANUFACTURING L.L.C. 5601 San Francisco St. NE Albuquerque, N.M. 87109 (505) 924-2810	
SIZE		DWG NO:		TW1102	
H.D.G.		DRAWN BY:		DATE: 7/2/2021	
		E.FILMER		DATE: 7/2/2021	
		SHEET: 1 of 1		SCALE: NTS	
				REV	
				WEIGHT: 8.81	