

ITEM NO.	PART NUMBER	DESCRIPTION	FINISH	WEIGHT (PER)	QTY.
1	WT1250.05	UPPER BRACKET (3/8" PLATE)	H.D.G.	9.63	1
2	WT1250.06	LOWER BRACKET (WELDMENT)	H.D.G.	9.40	1
3	GU42440	1/2" x 4" x 2-1/2" x 2" U-BOLT	H.D.G.	0.57	2
4	GB0414A	1/2 X 1-1/2 BOLT	H.D.G.	0.15	2
5	GL04	1/2" LOCK WASHER	H.D.G.	0.02	6
6	GN04A	1/2" HEX NUT (2H)	H.D.G.	0.06	6
7	GF04	1/2" FLAT WASHER	H.D.G.	0.04	4
8	GF04A	1/2" FLAT WASHER	H.D.G.	0.02	2

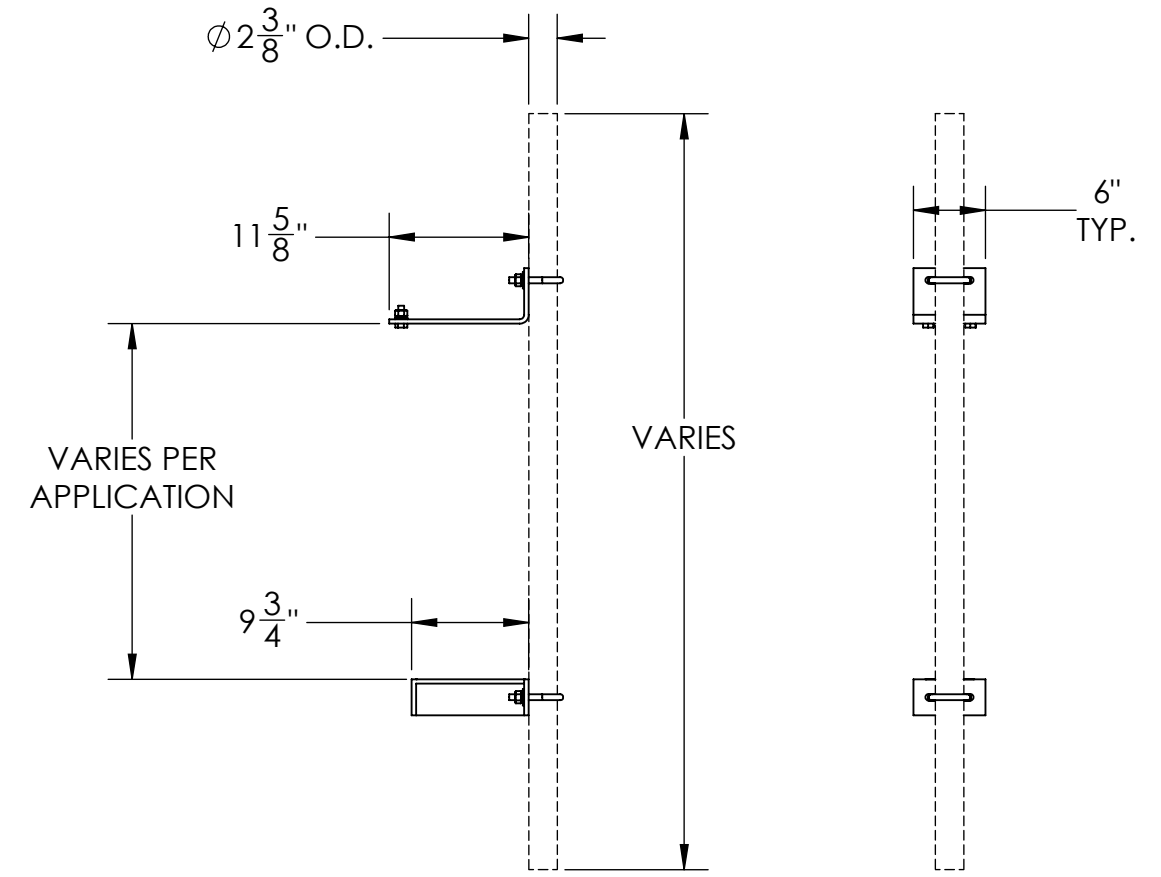
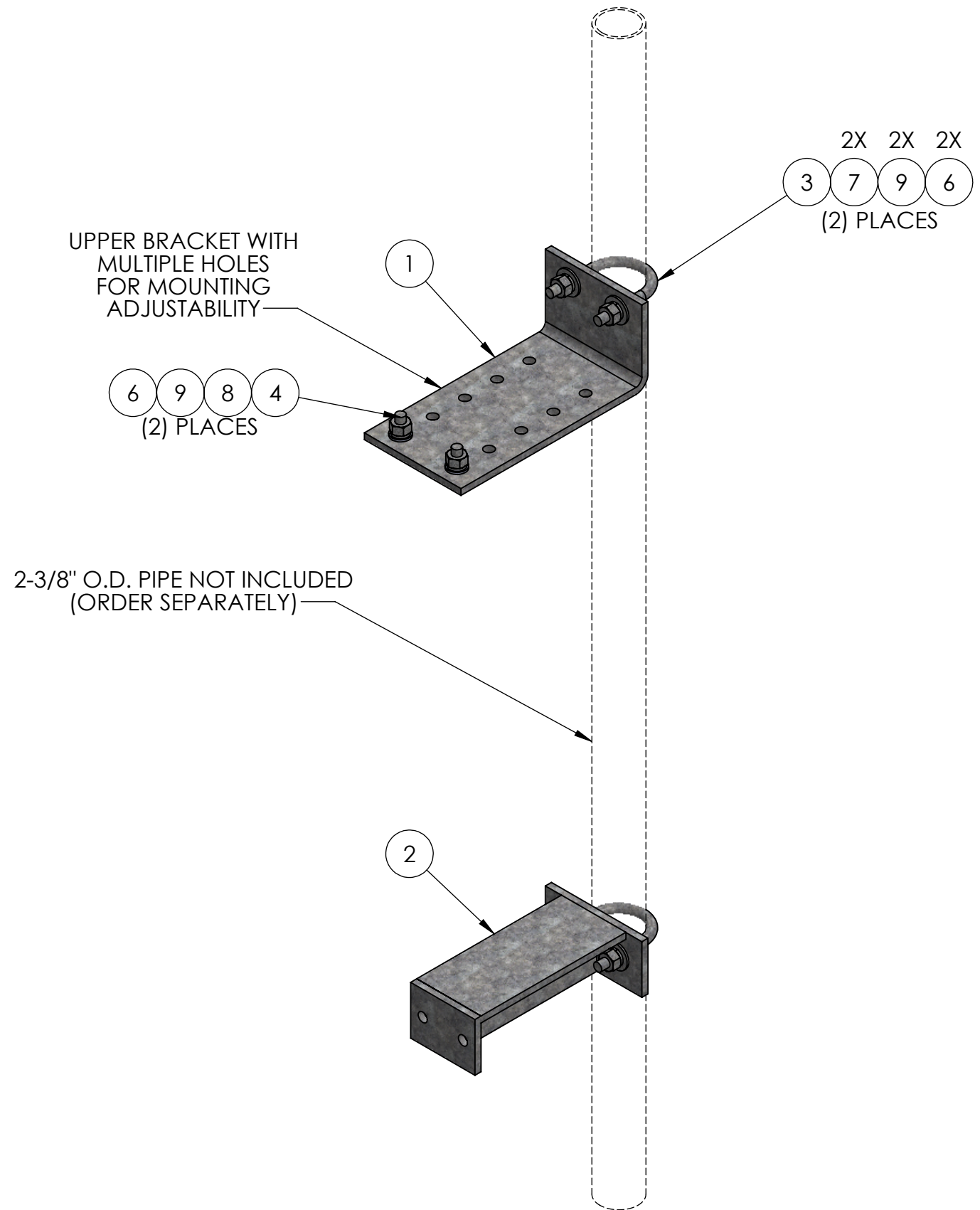

UNLESS OTHERWISE SPECIFIED: DIMENSIONS ARE IN INCHES TOLERANCE $\pm 1/16$		DESCRIPTION: WATER TOWER UPPER SUPPORT RAIL MOUNT FOR 2-3/8" O.D.	
MATERIAL: -		 PRO TOWER MANUFACTURING L.L.C. 5601 San Francisco St. NE Albuquerque, N.M. 87109 (505) 924-2810	DWG NO: WT1250
FINISH: H.D.G.			DRAWN BY: AJK CHECKED BY: E.FILMER SHEET: 1 of 1
SIZE: B	PROPRIETARY AND CONFIDENTIAL THE INFORMATION CONTAINED IN THIS DRAWING IS THE SOLE PROPERTY OF PRO TOWER MANUFACTURING L.L.C. ANY REPRODUCTION IN PART OR AS A WHOLE WITHOUT THE WRITTEN PERMISSION OF PRO TOWER MANUFACTURING L.L.C. IS PROHIBITED.	DATE: 12/5/2022 DATE: 12/5/2022 SCALE: NTS	REV WEIGHT: 21.15