

ITEM NO.	PART NO.	DESCRIPTION	MATERIAL	FINISH	QTY.
1	WT1302.01 RM	30" LEG BRACKET RING MOUNT (1/8"PL x 2" x 59-1/4")	A36	H.D.G.	2
2	WT1302.01 CM	30" LEG BRACKET COAX MOUNT (1/8"PL x 2" x 52-1/16")	A36	H.D.G.	1
3	WT13XX GUSSET PLATE	GUSSET PLATE (1/8"PL)	A36	H.D.G.	8
4	WT13XX SUPPORT PLATE	SUPPORT PLATE (1/8"PL x 1" x 2")	A36	H.D.G.	1
5	GR375.006	3/8" x 6" GALV THREADED ROD	GR.5	H.D.G.	2
6	GL03	3/8" LOCK WASHER	GR.5	H.D.G.	4
7	GN03	3/8" HEX NUT	GR.5	H.D.G.	4

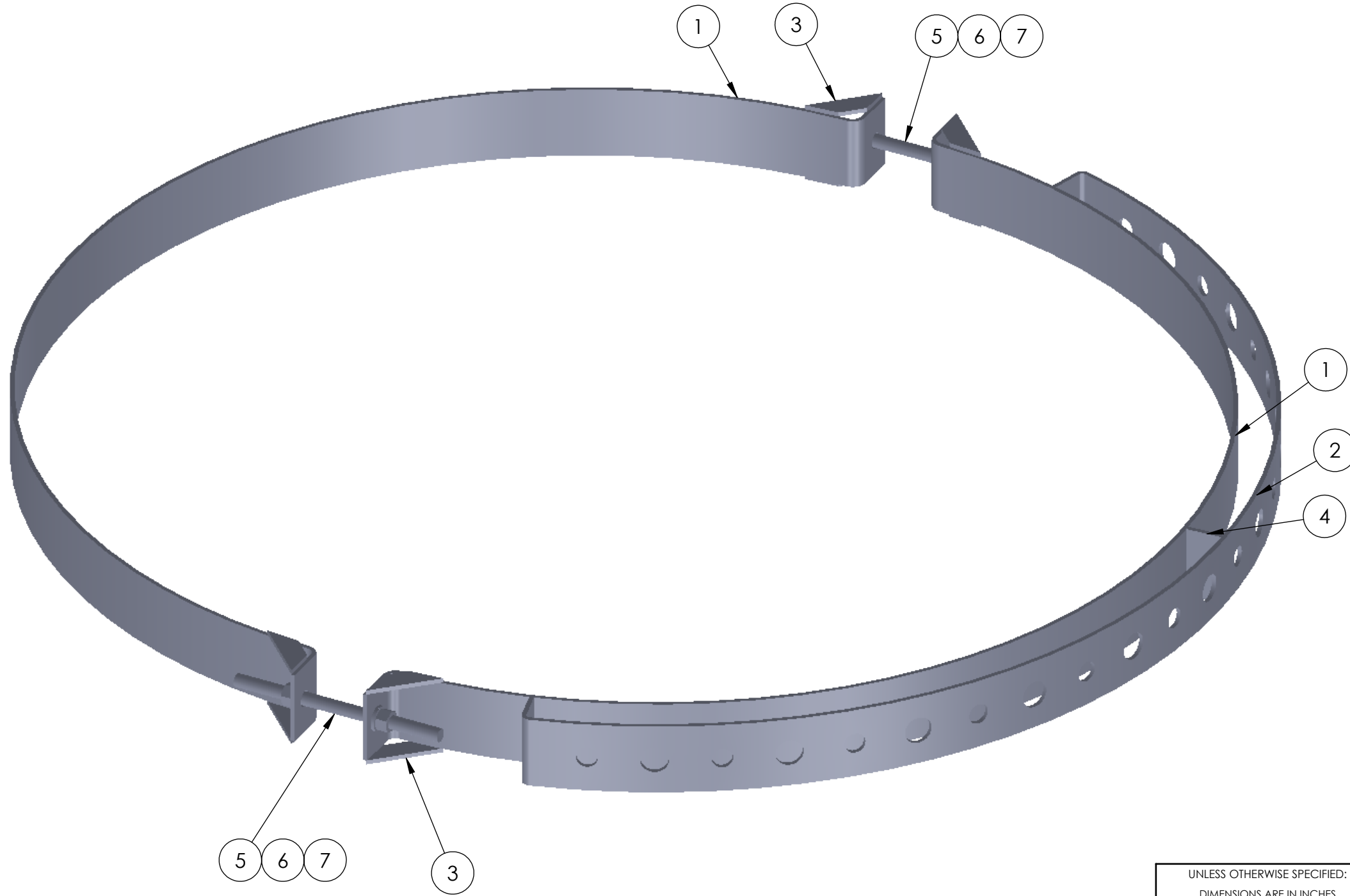

UNLESS OTHERWISE SPECIFIED: DIMENSIONS ARE IN INCHES TOLERANCE ± 1/16		DESCRIPTION: 30" WATER TOWER LEG BRACKET	
PROPRIETARY AND CONFIDENTIAL THE INFORMATION CONTAINED IN THIS DRAWING IS THE SOLE PROPERTY OF PRO TOWER MANUFACTURING L.L.C. ANY REPRODUCTION IN PART OR AS A WHOLE WITHOUT THE WRITTEN PERMISSION OF PRO TOWER MANUFACTURING L.L.C. IS PROHIBITED.		 PRO TOWER MANUFACTURING L.L.C. 5601 San Francisco St. NE Albuquerque, N.M. 87109 (505) 924-2810	DWG NO: WT1302
			DRAWN BY: C. AIKIN CHECKED BY: T.SMYTHE SHEET: 1 of 6

ITEM NO.	PART NO.	DESCRIPTION	MATERIAL	FINISH	QTY.
1	WT1302.01 RM	30" LEG BRACKET RING MOUNT (1/8"PL x 2" x 59-1/4")	A36	H.D.G.	1
2	WT13XX GUSSET PLATE	GUSSET PLATE (1/8"PL)	A36	H.D.G.	4

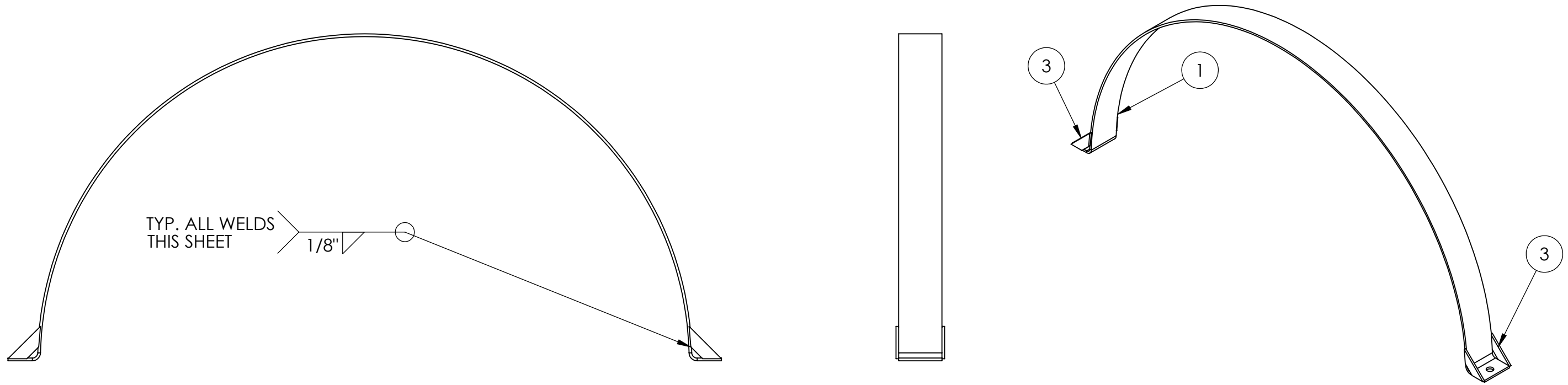

UNLESS OTHERWISE SPECIFIED: DIMENSIONS ARE IN INCHES TOLERANCE ± 1/16		DESCRIPTION: 30" LEG BRACKET RING MOUNT BRACKET	
PRO TOWER MANUFACTURING L.L.C. 5601 San Francisco St. NE Albuquerque, N.M. 87109 (505) 924-2810		DWG NO: WT1302.01	
		DRAWN BY: C. AIKIN CHECKED BY: T.SMYTHE SHEET: 2 of 6	DATE: 9/18/2019 DATE: 9/18/2019 SCALE: NTS

ITEM NO.	PART NO.	DESCRIPTION	MATERIAL	FINISH	QTY.
1	WT1302.01 RM	30" LEG BRACKET RING MOUNT (1/8"PL x 2" x 59-1/4")	A36	H.D.G.	1
2	WT1302.01 CM	30" LEG BRACKET COAX MOUNT (1/8"PL x 2" x 52-1/16")	A36	H.D.G.	1
3	WT13XX GUSSET PLATE	GUSSET PLATE (1/8"PL)	A36	H.D.G.	4
4	WT13XX SUPPORT PLATE	SUPPORT PLATE (1/8"PL x 1" x 2")	A36	H.D.G.	1

POSITION SUPPORT IN BETWEEN HOLES
TO AVOID HOLE INTERFERENCE

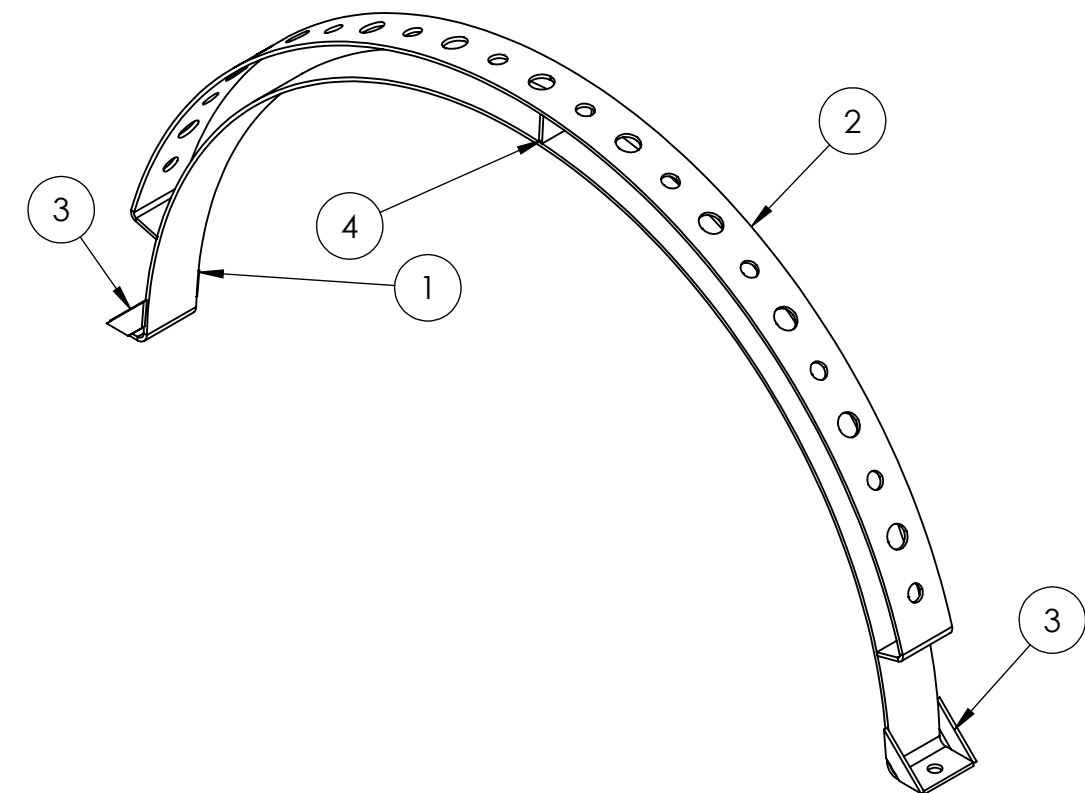
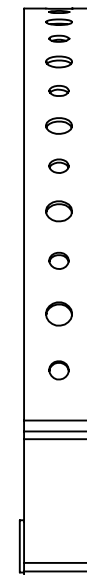
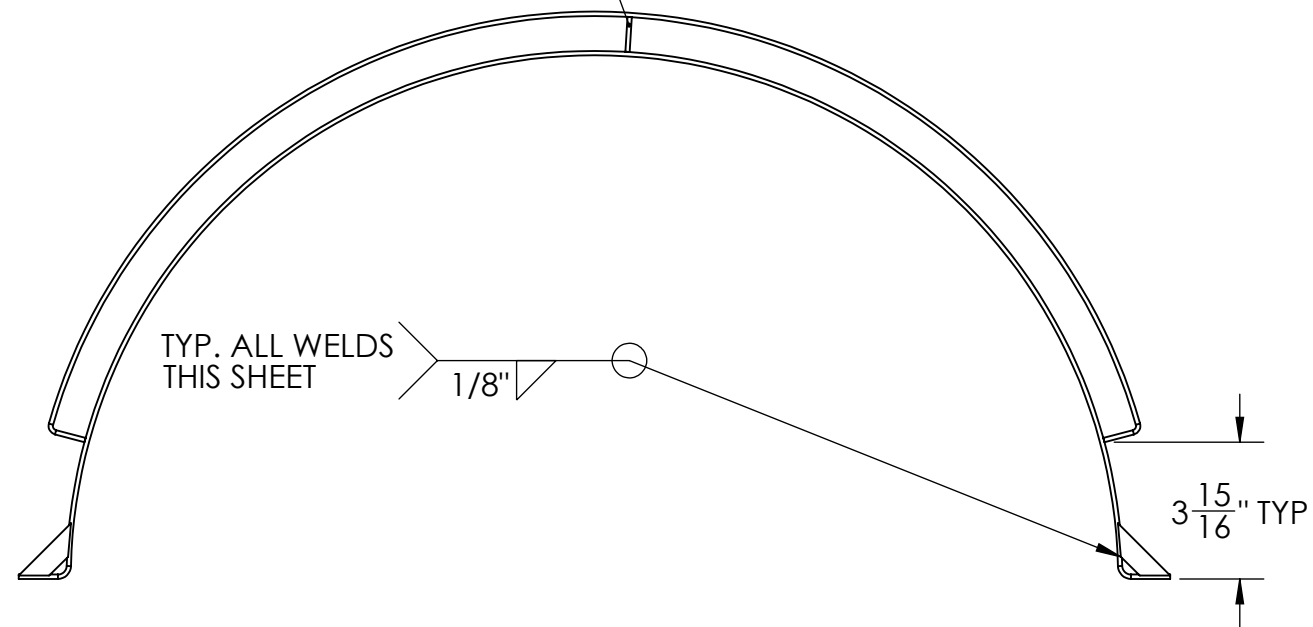

UNLESS OTHERWISE SPECIFIED: DIMENSIONS ARE IN INCHES TOLERANCE ± 1/16	DESCRIPTION:	30" LEG BRACKET COAX MOUNT BRACKET		
	PRO TOWER MANUFACTURING L.L.C. 5601 San Francisco St. NE Albuquerque, N.M. 87109 (505) 924-2810	DWG NO:	WT1302.02	
DRAWN BY:		DATE:	REV:	
CHECKED BY:		DATE:	WEIGHT:	
PROPRIETARY AND CONFIDENTIAL THE INFORMATION CONTAINED IN THIS DRAWING IS THE SOLE PROPERTY OF PRO TOWER MANUFACTURING L.L.C. ANY REPRODUCTION IN PART OR AS A WHOLE WITHOUT THE WRITTEN PERMISSION OF PRO TOWER MANUFACTURING L.L.C. IS PROHIBITED.		T.SMYTHE SHEET: 3 of 6	9/18/2019 9/18/2019 NTS	

ITEM NO.	PART NO.	DESCRIPTION	MATERIAL	FINISH	QTY.
1	WT1302.01 CM	30" LEG BRACKET COAX MOUNT (1/8" PL x 2" x 52-1/16")	A36	H.D.G.	1

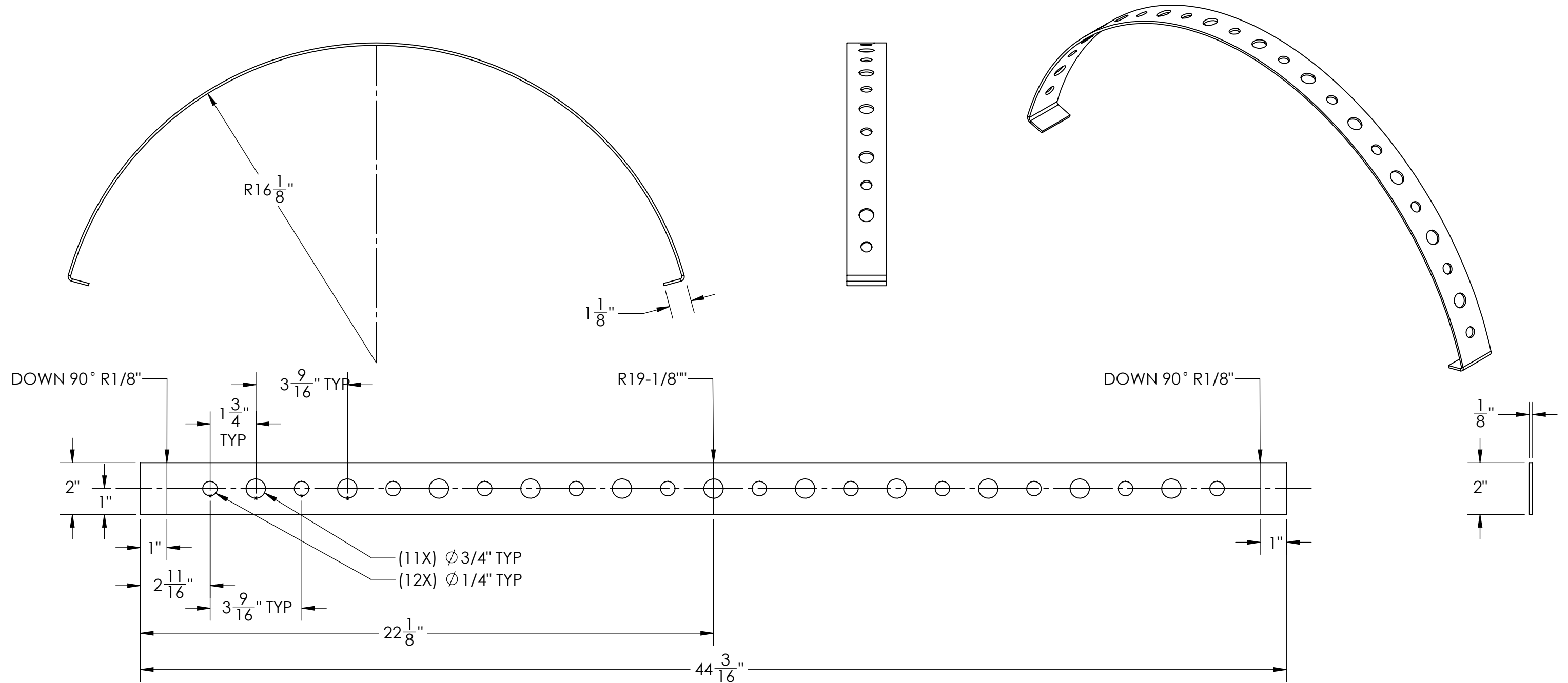

UNLESS OTHERWISE SPECIFIED: DIMENSIONS ARE IN INCHES TOLERANCE $\pm \frac{1}{16}$	DESCRIPTION:	30" LEG BRACKET COAX MOUNT		
	PRO TOWER MANUFACTURING L.L.C. 5601 San Francisco St. NE Albuquerque, N.M. 87109 (505) 924-2810	DWG NO:	WT1302.01 CM	
DRAWN BY:		DATE:	REV:	
C. AIKIN		9/18/2019		
CHECKED BY:		DATE:	WEIGHT:	
T.SMYTHE	9/18/2019			
SHEET:	4 of 6	SCALE:	NTS	

ITEM NO.	PART NO.	DESCRIPTION	MATERIAL	FINISH	QTY.
1	WT1302.01 RM	30" LEG BRACKET RING MOUNT (1/8" PL x 2" x 59-1/4")	A36	H.D.G.	2

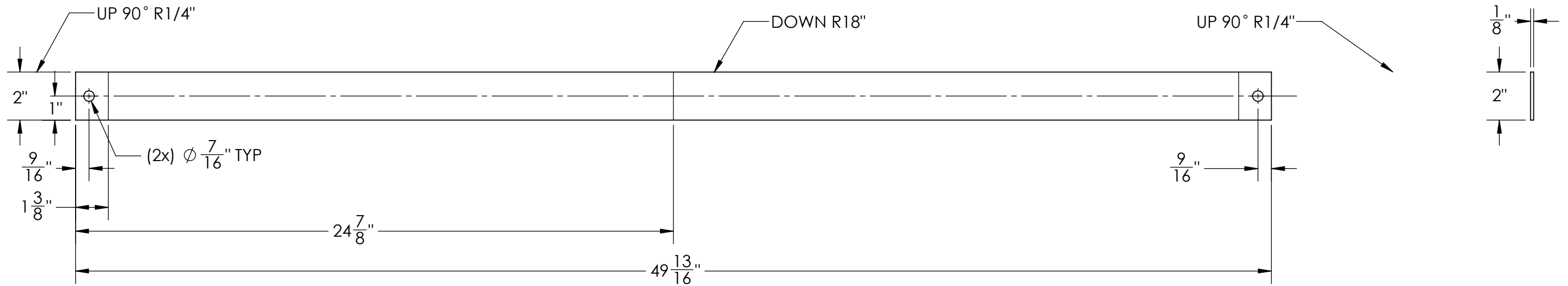
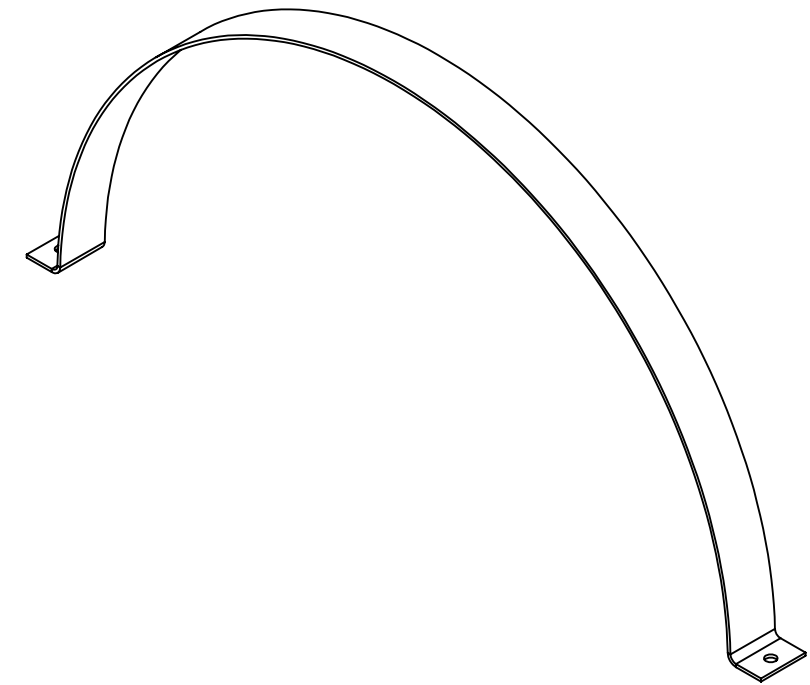
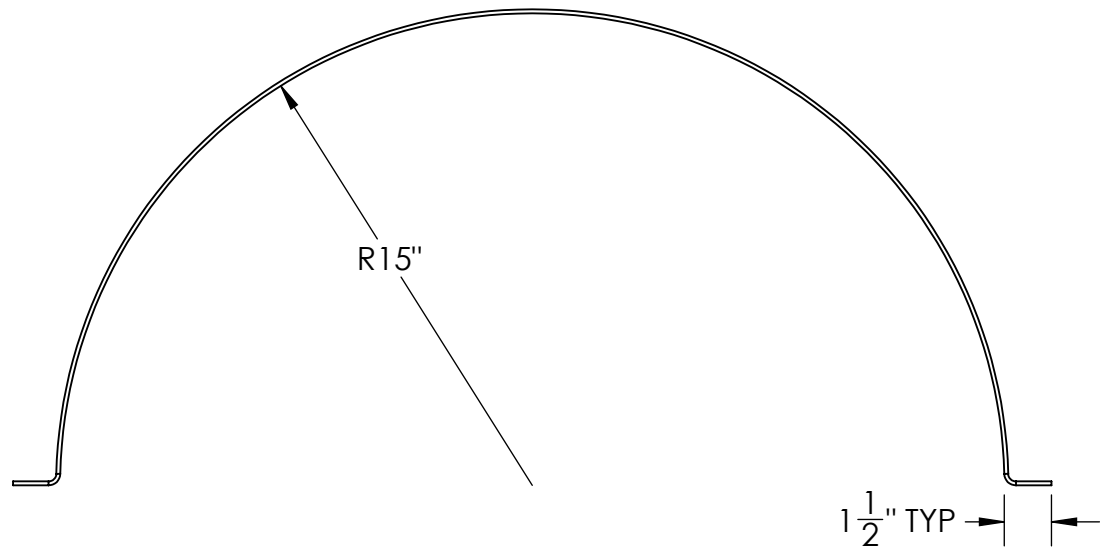

UNLESS OTHERWISE SPECIFIED: DIMENSIONS ARE IN INCHES TOLERANCE $\pm 1/16$	DESCRIPTION: 30" LEG BRACKET RING MOUNT			
	DWG NO: WT1302.01 RM			
PROPRIETARY AND CONFIDENTIAL THE INFORMATION CONTAINED IN THIS DRAWING IS THE SOLE PROPERTY OF PRO TOWER MANUFACTURING L.L.C. ANY REPRODUCTION IN PART OR AS A WHOLE WITHOUT THE WRITTEN PERMISSION OF PRO TOWER MANUFACTURING L.L.C. IS PROHIBITED.	 PRO TOWER MANUFACTURING L.L.C. 5601 San Francisco St. NE Albuquerque, N.M. 87109 (505) 924-2810	DRAWN BY: C. AIKIN	DATE: 9/18/2019	REV
		CHECKED BY: T.SMYTHE	DATE: 9/18/2019	WEIGHT:
		SHEET: 5 of 6	SCALE: NTS	

ITEM NO.	PART NO.	DESCRIPTION	MATERIAL	FINISH	QTY.
1	WT13XX GUSSET PLATE	GUSSET PLATE (1/8"PL)	A36	H.D.G.	8
2	WT13XX SUPPORT PLATE	SUPPORT PLATE (1/8"PL x 1" x 2")	A36	H.D.G.	1

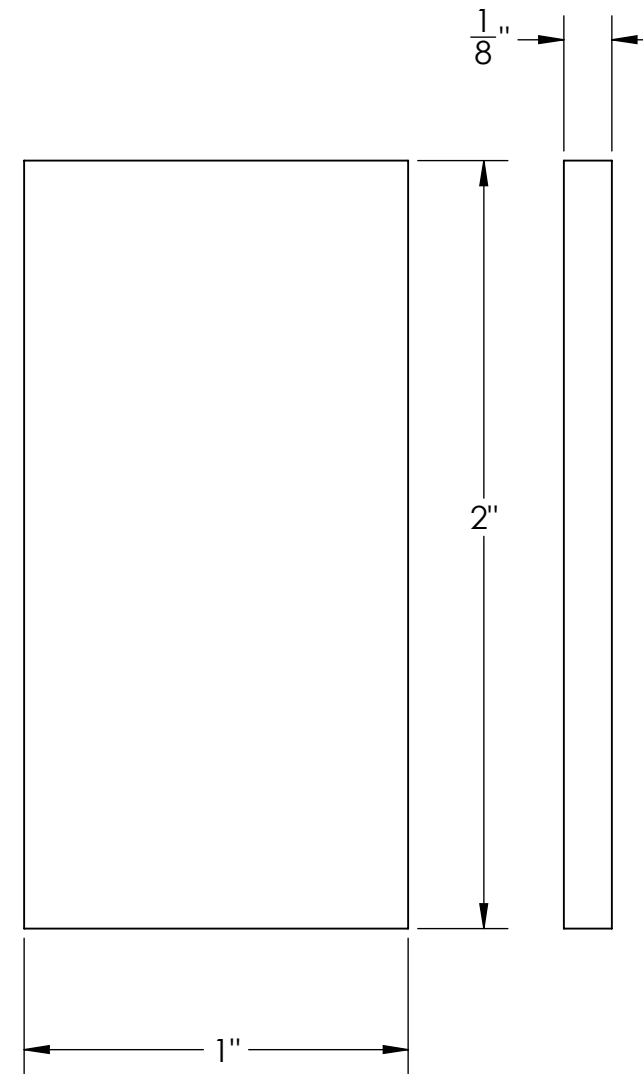
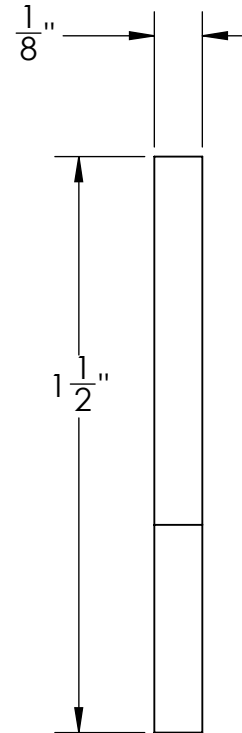
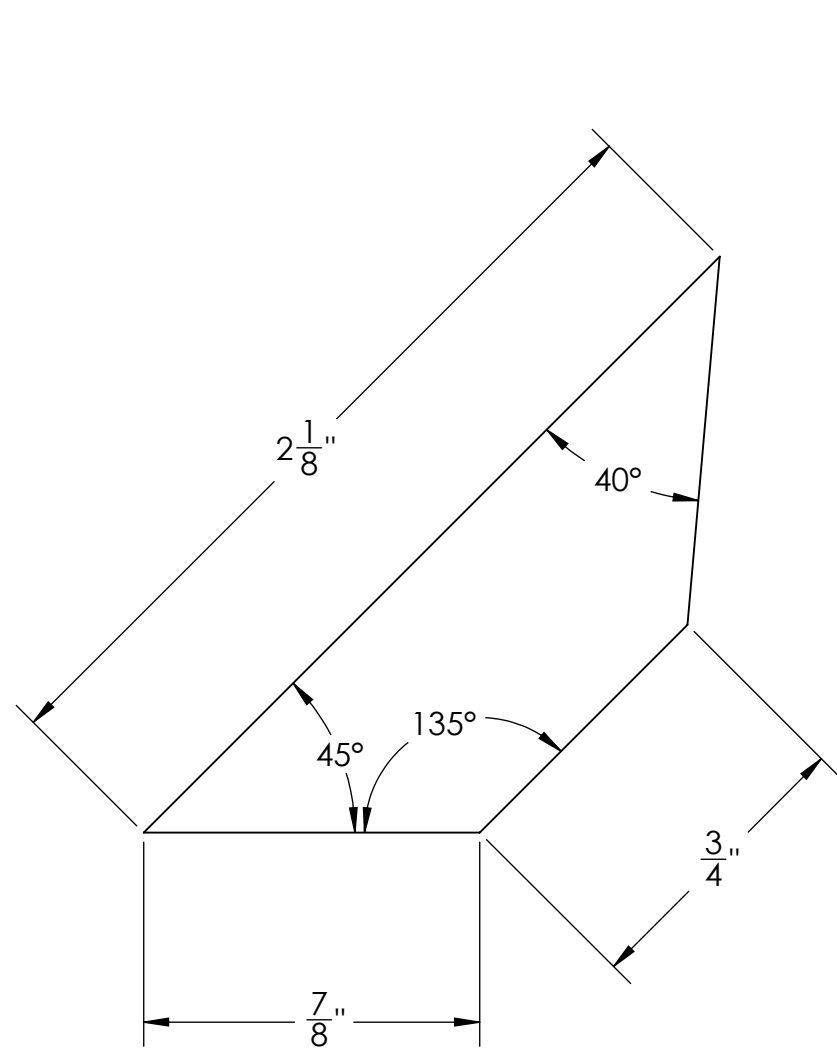

UNLESS OTHERWISE SPECIFIED: DIMENSIONS ARE IN INCHES TOLERANCE ± 1/16	DESCRIPTION: PLATE PARTS			
	DWG NO: WT1302			
PROPRIETARY AND CONFIDENTIAL THE INFORMATION CONTAINED IN THIS DRAWING IS THE SOLE PROPERTY OF PRO TOWER MANUFACTURING L.L.C. ANY REPRODUCTION IN PART OR AS A WHOLE WITHOUT THE WRITTEN PERMISSION OF PRO TOWER MANUFACTURING L.L.C. IS PROHIBITED.	 PRO TOWER MANUFACTURING L.L.C. 5601 San Francisco St. NE Albuquerque, N.M. 87109 (505) 924-2810	DRAWN BY: C. AIKIN	DATE: 9/18/2019	REV
		CHECKED BY: T.SMYTHE	DATE: 9/18/2019	WEIGHT:
		SHEET: 6 of 6	SCALE: NTS	