

ITEM NO.	PART NO.	DESCRIPTION	MATERIAL	FINISH	QTY.
1	WT1306.01 RM	42" LEG BRACKET RING MOUNT (1/8"PL x 2" x 68-5/8")	A36	H.D.G.	2
2	WT1306.01 CM	42" LEG BRACKET COAX MOUNT (1/8"PL x 2" x 59-15/16")	A36	H.D.G.	1
3	WT13XX GUSSET PLATE	GUSSET PLATE (1/8"PL)	A36	H.D.G.	8
4	WT13XX SUPPORT PLATE	SUPPORT PLATE (1/8"PL x 1" x 2")	A36	H.D.G.	1
5	GR375.006	3/8" x 6" GALV THREADED ROD	GR.5	H.D.G.	2
6	GL03	3/8" LOCK WASHER	GR.5	H.D.G.	4
7	GN03	3/8" HEX NUT	GR.5	H.D.G.	4

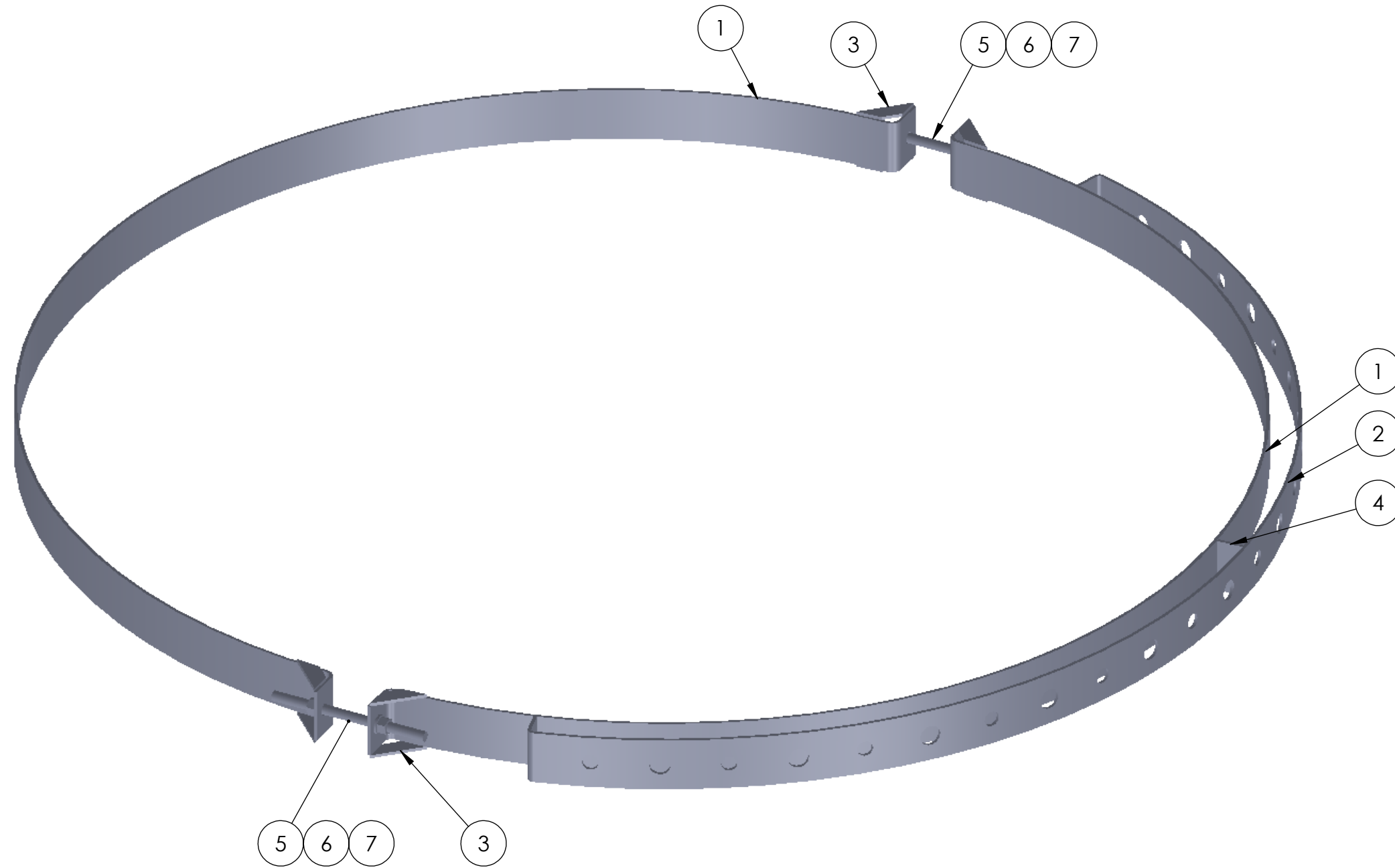

UNLESS OTHERWISE SPECIFIED: DIMENSIONS ARE IN INCHES TOLERANCE $\pm 1/16$		DESCRIPTION: 42" WATER TOWER LEG BRACKET	
PROPRIETARY AND CONFIDENTIAL THE INFORMATION CONTAINED IN THIS DRAWING IS THE SOLE PROPERTY OF PRO TOWER MANUFACTURING L.L.C. ANY REPRODUCTION IN PART OR AS A WHOLE WITHOUT THE WRITTEN PERMISSION OF PRO TOWER MANUFACTURING L.L.C. IS PROHIBITED.		 PRO TOWER MANUFACTURING L.L.C. 5601 San Francisco St. NE Albuquerque, N.M. 87109 (505) 924-2810	DWG NO: WT1306
			DRAWN BY: C. AIKIN CHECKED BY: T.SMYTHE SHEET: 1 of 6

ITEM NO.	PART NO.	DESCRIPTION	MATERIAL	FINISH	QTY.
1	WT1306.01 RM	42" LEG BRACKET RING MOUNT (1/8"PL x 2" x 68-5/8")	A36	H.D.G.	1
2	WT13XX GUSSET PLATE	GUSSET PLATE (1/8"PL)	A36	H.D.G.	4

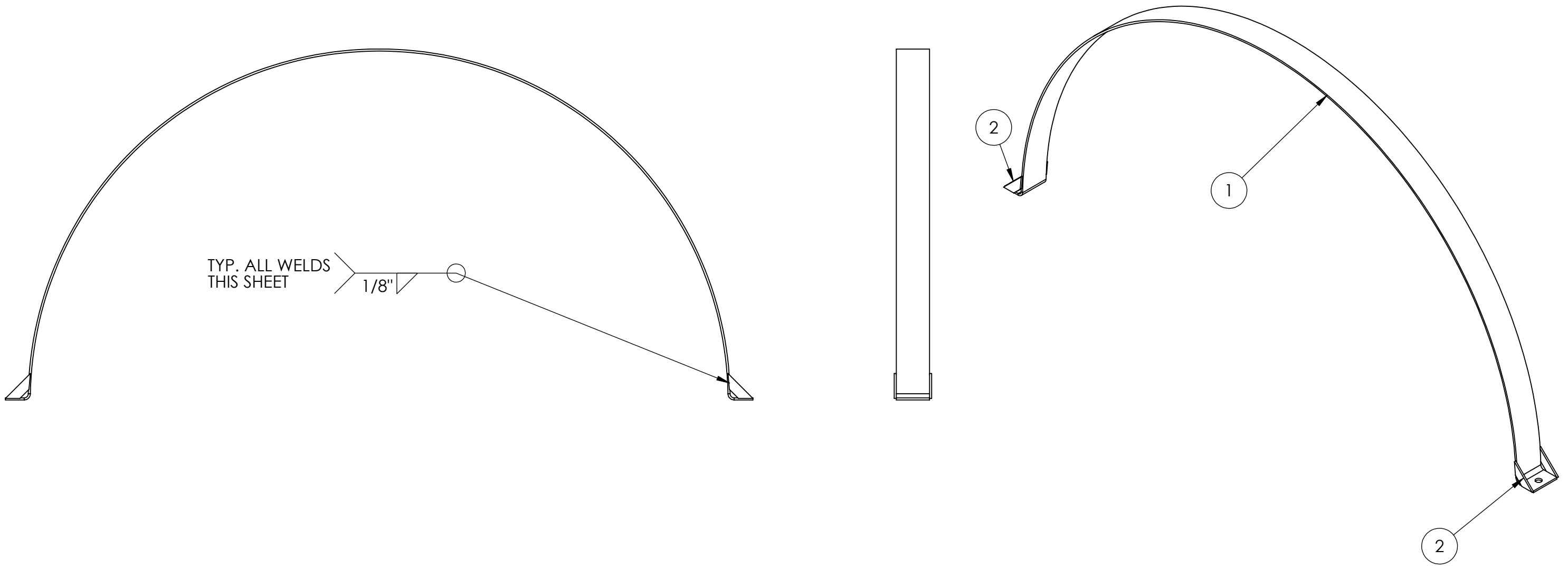

UNLESS OTHERWISE SPECIFIED: DIMENSIONS ARE IN INCHES TOLERANCE $\pm 1/16$	DESCRIPTION: 42" LEG BRACKET RING MOUNT BRACKET			
	DWG NO: WT1306.01			
PROPRIETARY AND CONFIDENTIAL THE INFORMATION CONTAINED IN THIS DRAWING IS THE SOLE PROPERTY OF PRO TOWER MANUFACTURING L.L.C. ANY REPRODUCTION IN PART OR AS A WHOLE WITHOUT THE WRITTEN PERMISSION OF PRO TOWER MANUFACTURING L.L.C. IS PROHIBITED.	 PRO TOWER MANUFACTURING L.L.C. 5601 San Francisco St. NE Albuquerque, N.M. 87109 (505) 924-2810	DRAWN BY: C. AIKIN	DATE: 9/10/2019	REV
		CHECKED BY: T.SMYTHE	DATE: 9/10/2019	WEIGHT:
		SHEET: 2 of 6	SCALE: NTS	

ITEM NO.	PART NO.	DESCRIPTION	MATERIAL	FINISH	QTY.
1	WT1306.01 RM	42" LEG BRACKET RING MOUNT (1/8"PL x 2" x 68-5/8")	A36	H.D.G.	1
2	WT1306.01 CM	42" LEG BRACKET COAX MOUNT (1/8"PL x 2" x 59-15/16")	A36	H.D.G.	1
3	WT13XX GUSSET PLATE	GUSSET PLATE (1/8"PL)	A36	H.D.G.	4
4	WT13XX SUPPORT PLATE	SUPPORT PLATE (1/8"PL x 1" x 2")	A36	H.D.G.	1

POSITION SUPPORT IN BETWEEN HOLES
TO AVOID HOLE INTERFERENCE

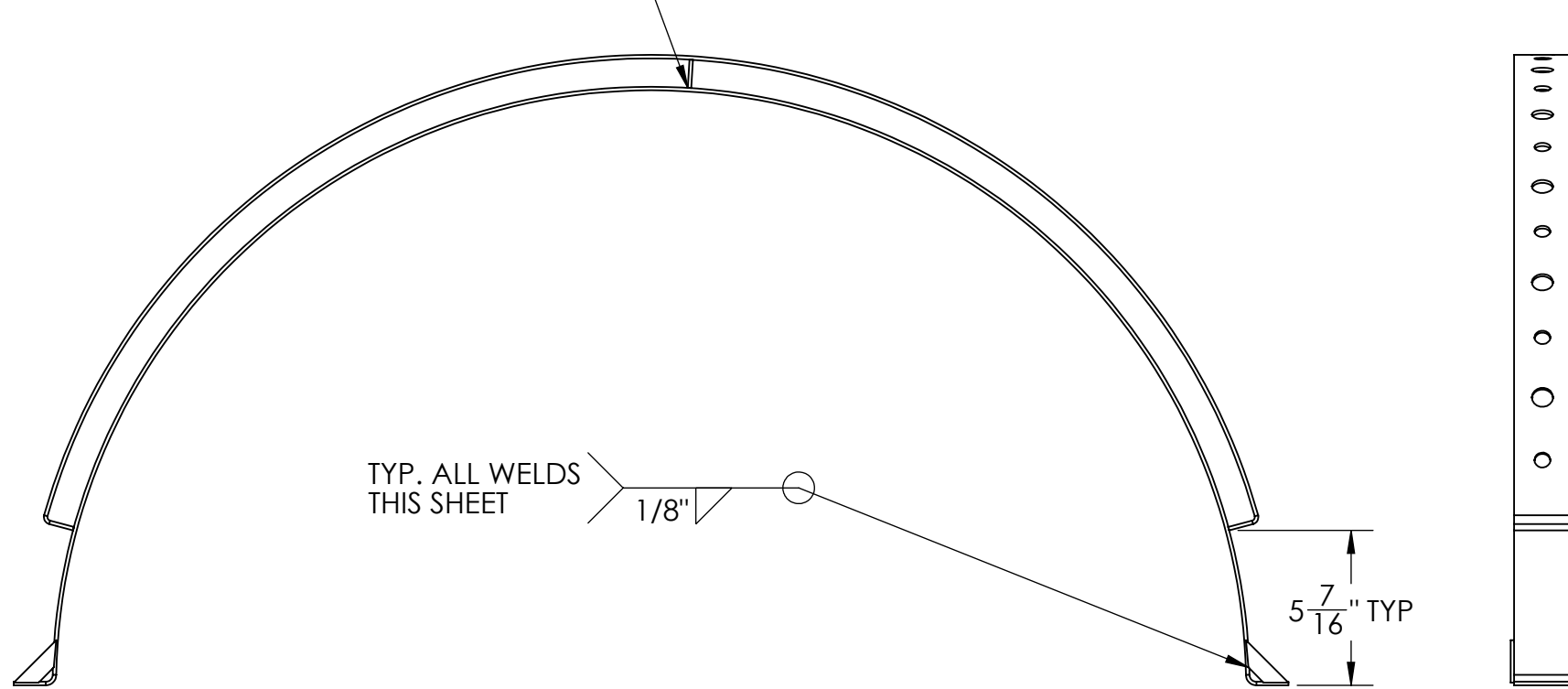

TYP. ALL WELDS
THIS SHEET

1/8"

5 7/16" TYP

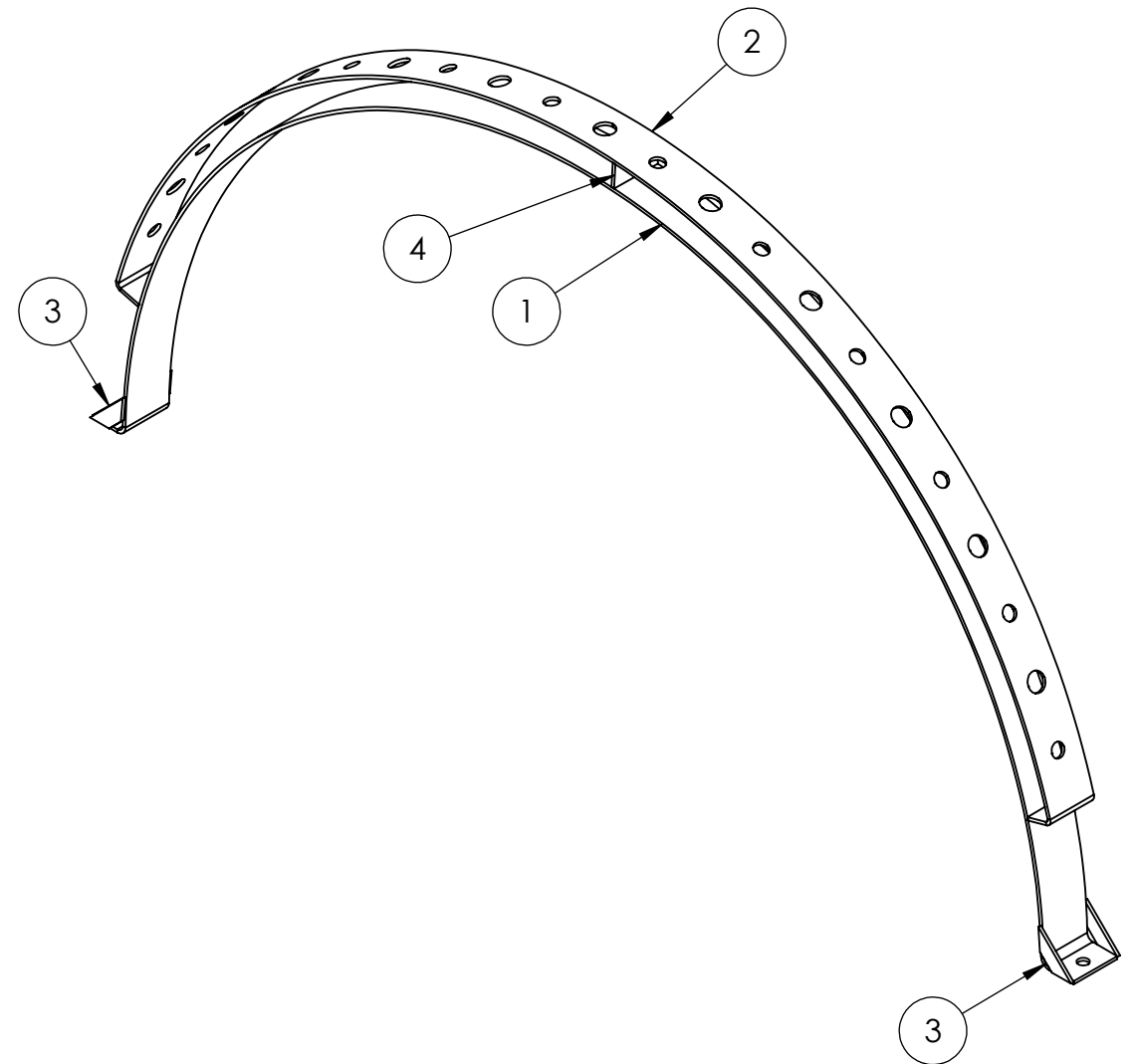

UNLESS OTHERWISE SPECIFIED: DIMENSIONS ARE IN INCHES TOLERANCE $\pm 1/16$		DESCRIPTION: 42" LEG BRACKET COAX MOUNT BRACKET	
PROPRIETARY AND CONFIDENTIAL THE INFORMATION CONTAINED IN THIS DRAWING IS THE SOLE PROPERTY OF PRO TOWER MANUFACTURING L.L.C. ANY REPRODUCTION IN PART OR AS A WHOLE WITHOUT THE WRITTEN PERMISSION OF PRO TOWER MANUFACTURING L.L.C. IS PROHIBITED.		PRO TOWER MANUFACTURING L.L.C. 5601 San Francisco St. NE Albuquerque, N.M. 87109 (505) 924-2810	
		DWG NO: WT1306.02 DRAWN BY: C. AIKIN CHECKED BY: T.SMYTHE SHEET: 3 of 6	
		DATE: 9/10/2019 DATE: 9/10/2019 SCALE: NTS	REV WEIGHT:

ITEM NO.	PART NO.	DESCRIPTION	MATERIAL	FINISH	QTY.
1	WT1306.01 CM	42" LEG BRACKET COAX MOUNT (1/8" PL x 2" x 59-15/16")	A36	H.D.G.	1

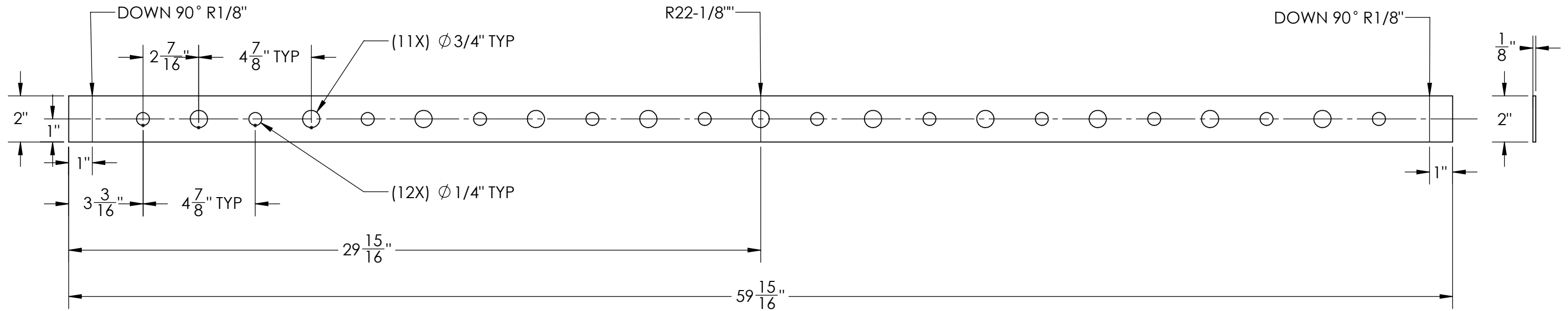
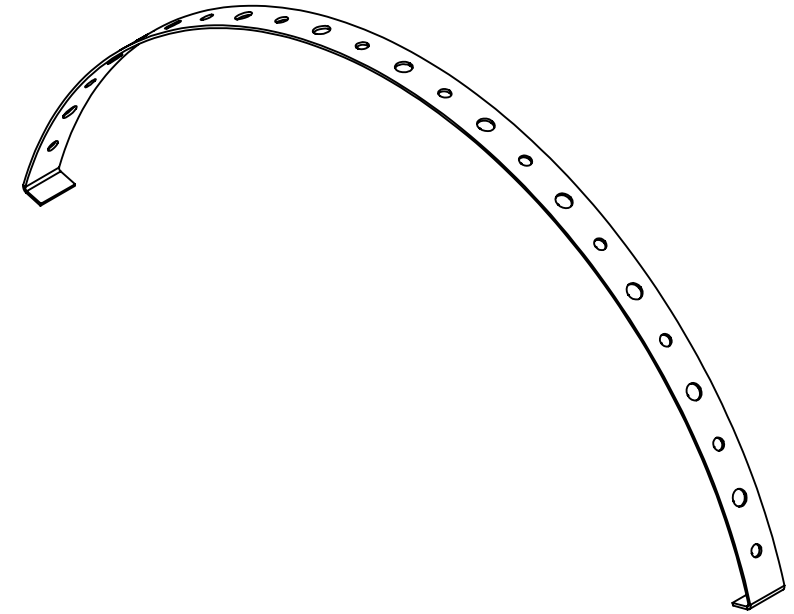
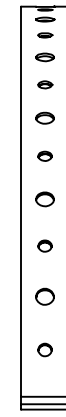
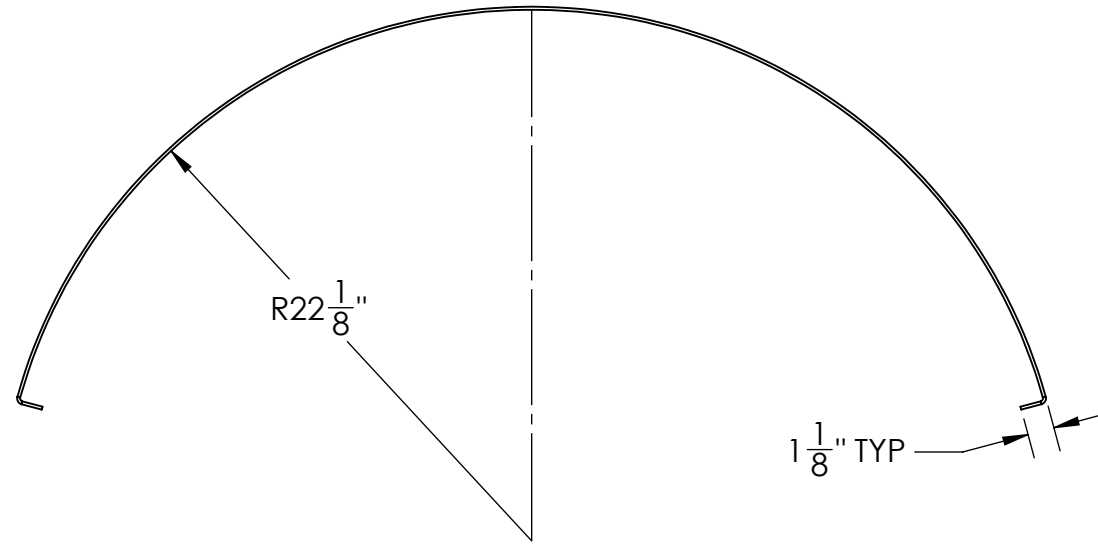

UNLESS OTHERWISE SPECIFIED: DIMENSIONS ARE IN INCHES TOLERANCE ± 1/16	DESCRIPTION: 42" LEG BRACKET COAX MOUNT	
	DWG NO: WT1306.01 CM	
PROPRIETARY AND CONFIDENTIAL THE INFORMATION CONTAINED IN THIS DRAWING IS THE SOLE PROPERTY OF PRO TOWER MANUFACTURING L.L.C. ANY REPRODUCTION IN PART OR AS A WHOLE WITHOUT THE WRITTEN PERMISSION OF PRO TOWER MANUFACTURING L.L.C. IS PROHIBITED.	PRO TOWER MANUFACTURING L.L.C. 5601 San Francisco St. NE Albuquerque, N.M. 87109 (505) 924-2810	DRAWN BY: C. AIKIN DATE: 9/10/2019 REV
		CHECKED BY: T.SMYTHE DATE: 9/10/2019 WEIGHT:
		SHEET: 4 of 6 SCALE: NTS
		(Empty)

ITEM NO.	PART NO.	DESCRIPTION	MATERIAL	FINISH	QTY.
1	WT13XX GUSSET PLATE	GUSSET PLATE (1/8"PL)	A36	H.D.G.	8
2	WT13XX SUPPORT PLATE	SUPPORT PLATE (1/8"PL x 1" x 2")	A36	H.D.G.	1

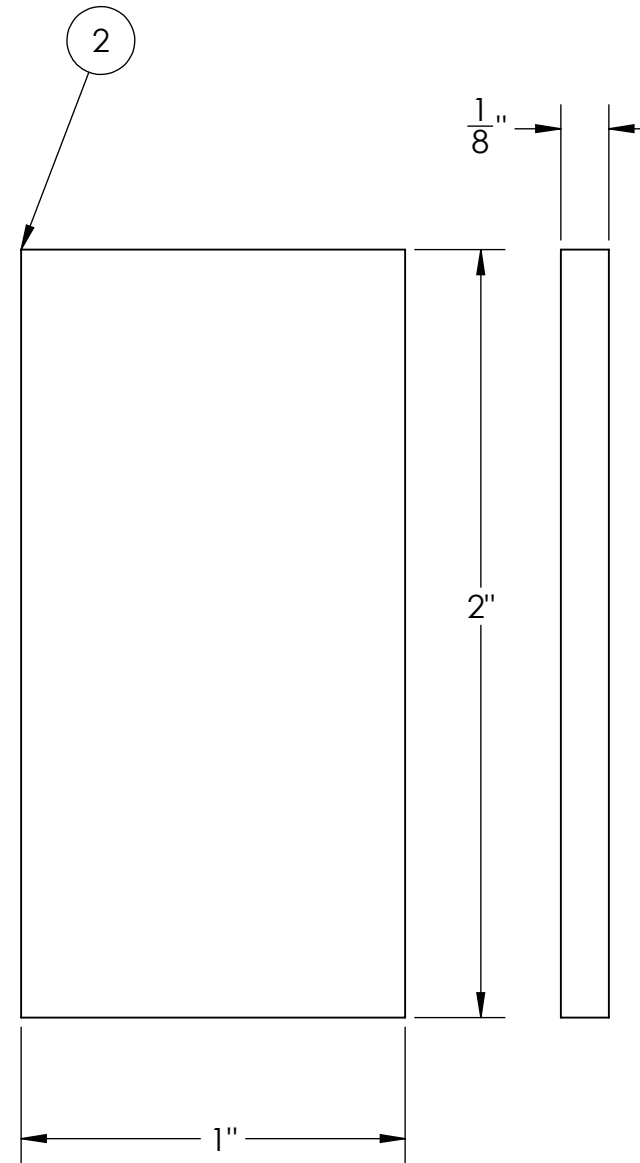
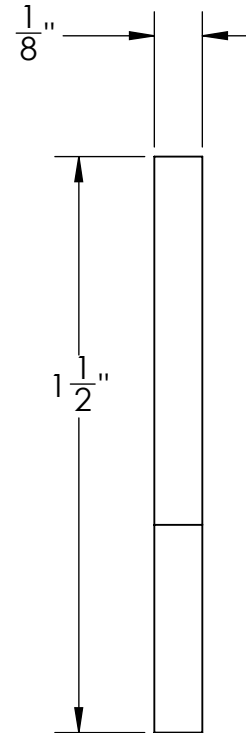
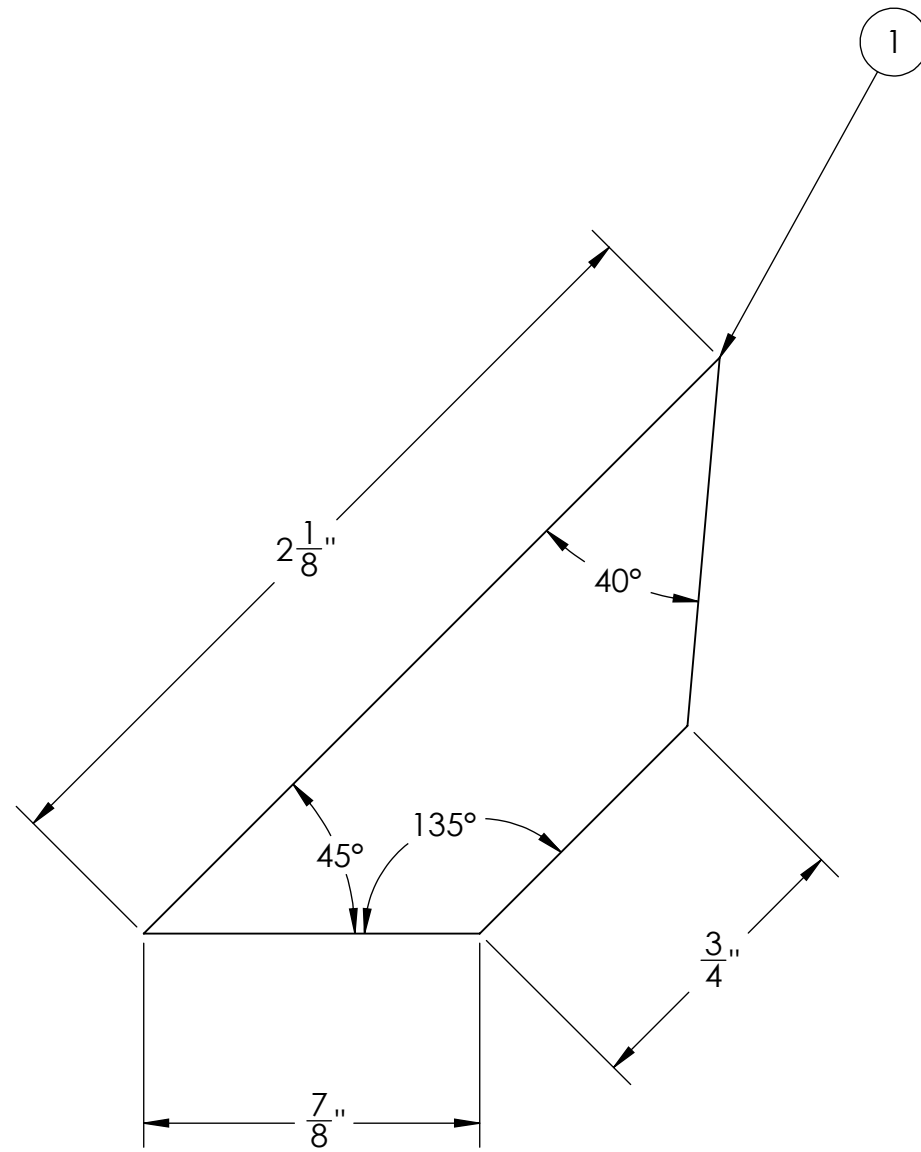

UNLESS OTHERWISE SPECIFIED: DIMENSIONS ARE IN INCHES TOLERANCE ± 1/16	DESCRIPTION: PLATE PARTS		
	PRO TOWER MANUFACTURING L.L.C. 5601 San Francisco St. NE Albuquerque, N.M. 87109 (505) 924-2810	DWG NO: WT1306	
DRAWN BY: C. AIKIN		DATE: 9/10/2019	REV
CHECKED BY: T.SMYTHE		DATE: 9/10/2019	WEIGHT:
SHEET: 6 of 6		SCALE: NTS	