

ITEM NO.	PART NUMBER	DESCRIPTION	FINISH	WEIGHT (PER)	QTY.
1	WT1320.01	36" Water Tower Expansion Mount half 1	H.D.G.	6.95	1
2	WT1320.02	36" Water Tower Expansion Mount half 2	H.D.G.	3.95	1
3	GR375.005	3/8" x 5" GALV THREADED ROD	H.D.G.	0.16	1
4	GL03	3/8" LOCK WASHER	H.D.G.	0.01	2
5	GN03	3/8" HEX NUT	H.D.G.	0.02	2
6	GB02245	1/4" x 2-1/2" GALV. BOLT	H.D.G.	0.04	1
7	GL02	1/4" LOCK WASHER	H.D.G.	0.01	1
8	GN02	1/4" HEX NUT	H.D.G.	0.01	1
9	GF02	1/4" FLAT WASHER	H.D.G.	0.01	1

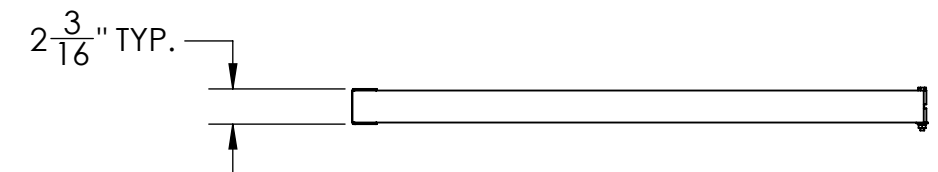
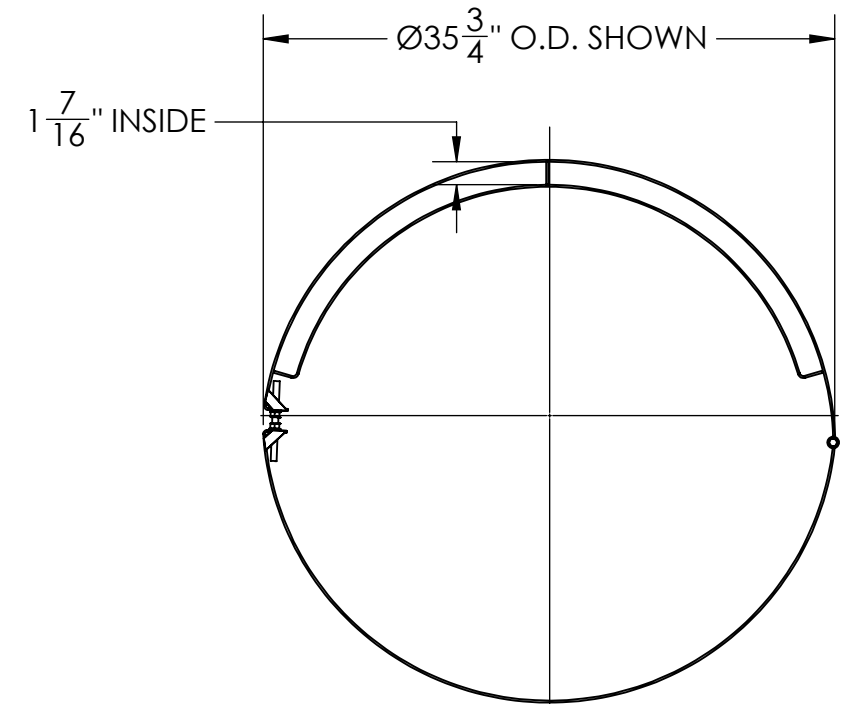
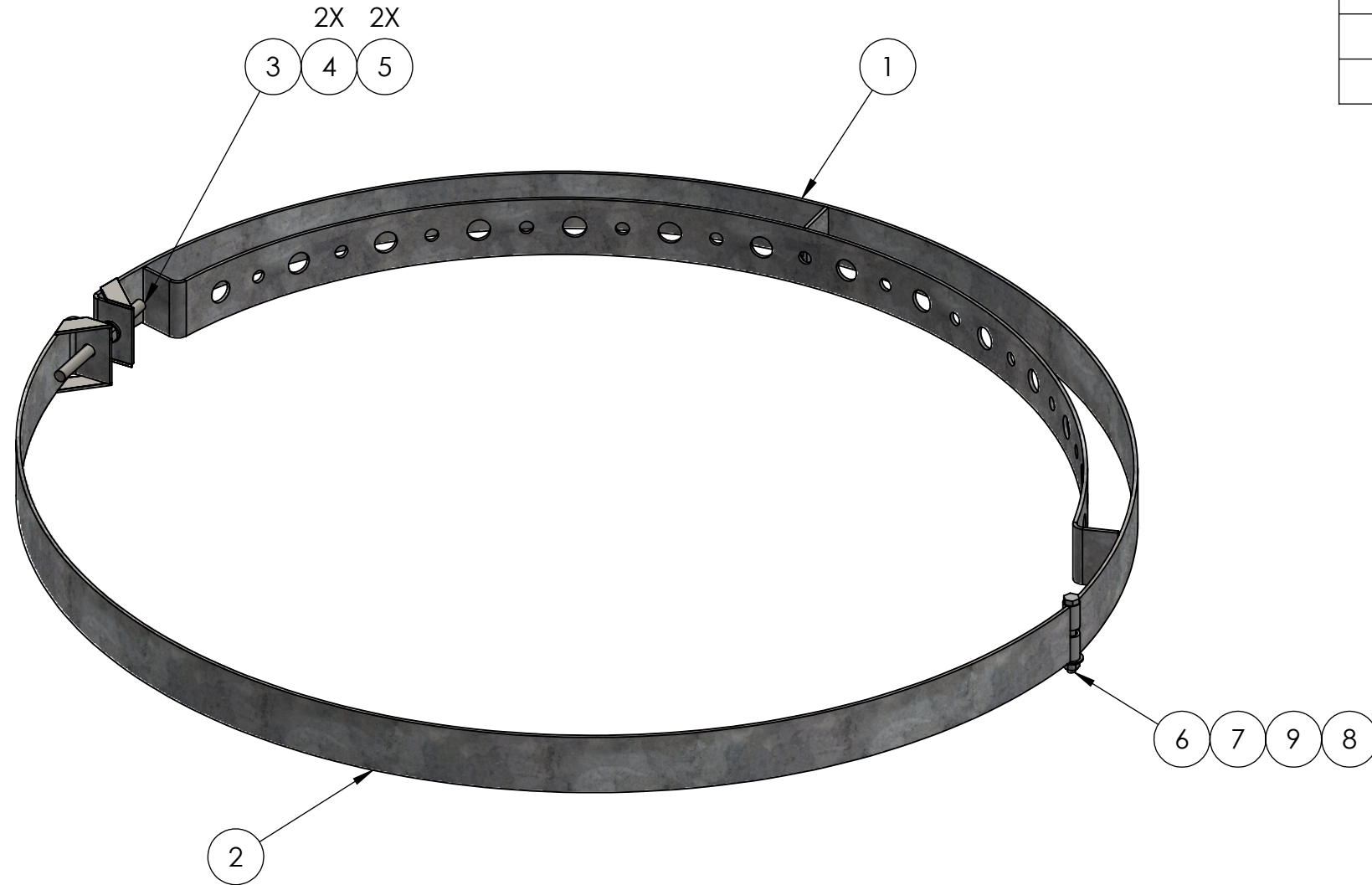

UNLESS OTHERWISE SPECIFIED: DIMENSIONS ARE IN INCHES TOLERANCE ± 1/16		DESCRIPTION: 36" Water Tower Expansion Bracket		
MATERIAL -		 PRO TOWER MANUFACTURING L.L.C. 5601 San Francisco St. NE Albuquerque, N.M. 87109 (505) 924-2810	DWG NO: WT1320	
FINISH H.D.G.			DRAWN BY: AJK CHECKED BY: E. FILMER SHEET: 1 of 1	DATE: 8/31/2022 DATE: 8/31/2022 SCALE: NTS