

ITEM NO.	PART NUMBER	DESCRIPTION	FINISH	WEIGHT (PER)	QTY.
1	WT1324.01	48" Water Tower Expansion Mount Half 1	H.D.G.	12.25	1
2	WT1324.02	48" Water Tower Expansion Mount Half 2	H.D.G.	7.91	1
3	GR375.005	3/8" x 5" GALV. ALL THREAD	H.D.G.	0.16	1
4	GL03	3/8" LOCK WASHER	H.D.G.	0.01	2
5	GN03	3/8" HEX NUT	H.D.G.	0.02	2
6	GB02245	1/4" X 2-1/2" HEX BOLT	H.D.G.	0.04	1
7	GL02	1/4" LOCK WASHER	H.D.G.	0.01	1
8	GN02	1/4" HEX NUT	H.D.G.	0.01	1
9	GF02	1/4" WASHER	H.D.G.	0.01	1

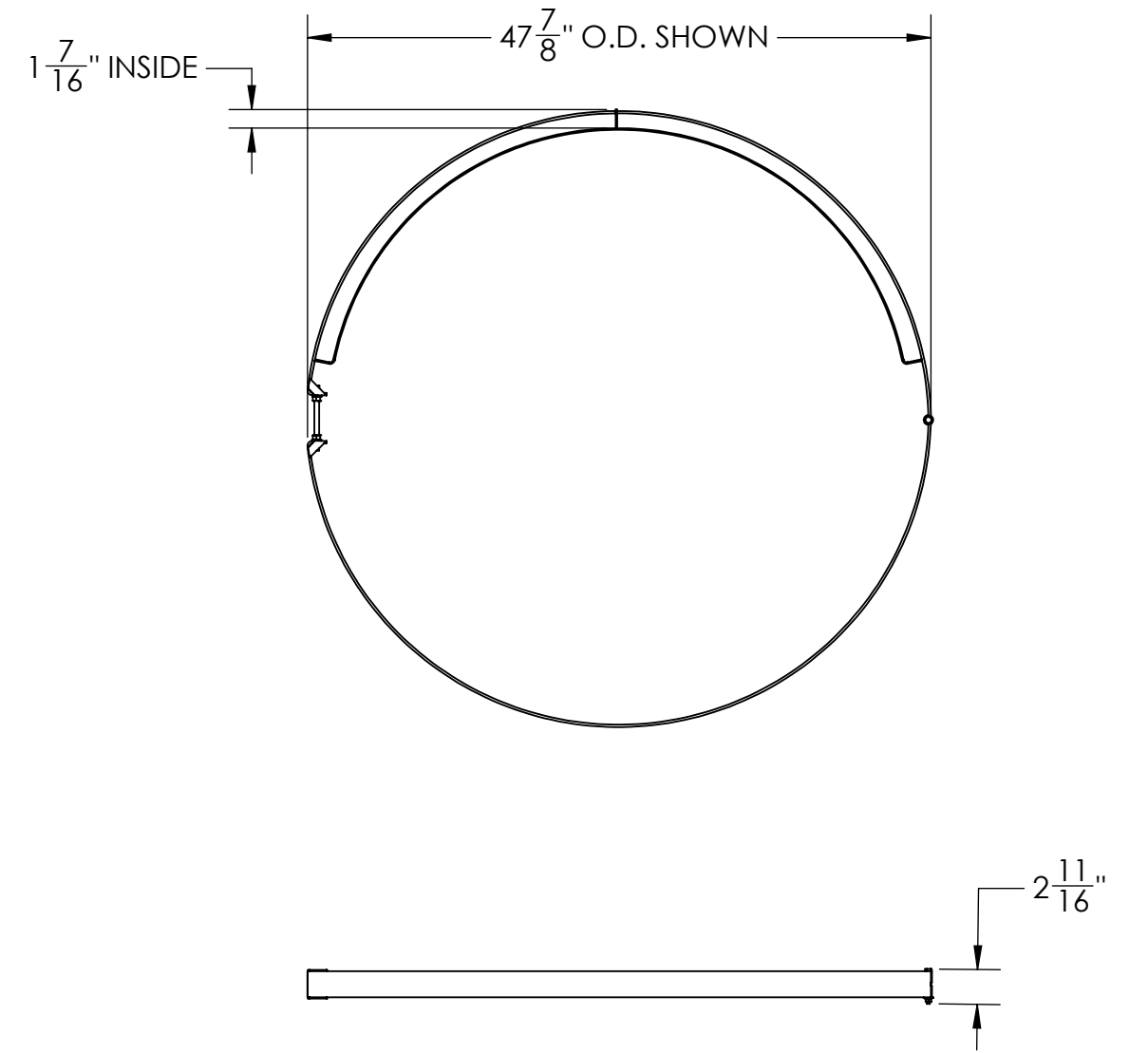
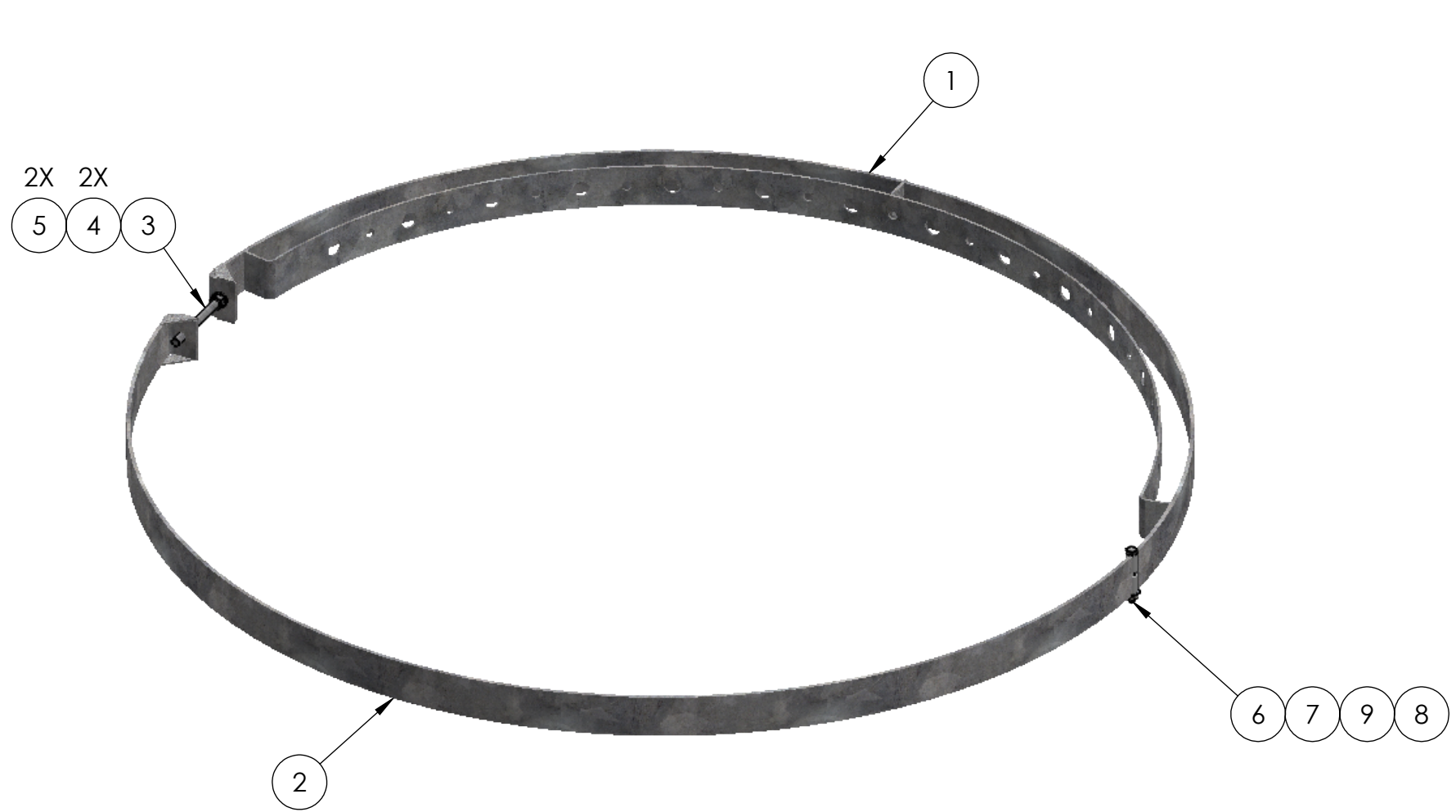

UNLESS OTHERWISE SPECIFIED: DIMENSIONS ARE IN INCHES TOLERANCE $\pm 1/16$		DESCRIPTION: 48" WATER TOWER EXPANSION BRACKET ASSEMBLY	
MATERIAL: -		 PRO TOWER MANUFACTURING L.L.C. 5601 San Francisco St. NE Albuquerque, N.M. 87109 (505) 924-2810	DWG NO: WT1324
FINISH: H.D.G.			DRAWN BY: AJK CHECKED BY: E. FILMER SHEET: 1 of 1
SIZE: B	PROPRIETARY AND CONFIDENTIAL THE INFORMATION CONTAINED IN THIS DRAWING IS THE SOLE PROPERTY OF PRO TOWER MANUFACTURING L.L.C. ANY REPRODUCTION IN PART OR AS A WHOLE WITHOUT THE WRITTEN PERMISSION OF PRO TOWER MANUFACTURING L.L.C. IS PROHIBITED.	REV: _____ WEIGHT: 20.43	