

ITEM NO.	PART NUMBER	DESCRIPTION	FINISH	WEIGHT (PER)	QTY.
1	WT1328.01	60" Water Tower Expansion Mount Half 1	H.D.G.	15.61	1
2	WT1328.02	60" Water Tower Expansion Mount Half 2	H.D.G.	9.92	1
3	GR375.008	3/8" X 8" GALV THREADED ROD	H.D.G.	0.25	1
4	GL03	3/8" LOCK WASHER	H.D.G.	0.01	2
5	GN03	3/8" HEX NUT	H.D.G.	0.02	2
6	GB02245	1/4" X 2-1/2" HEX BOLT	H.D.G.	0.04	1
7	GL02	1/4" STD LOCK WASHER	H.D.G.	0.01	1
8	GN02	1/4" HEX NUT	H.D.G.	0.01	1
9	GF02	1/4" FLAT WASHER	H.D.G.	0.01	1

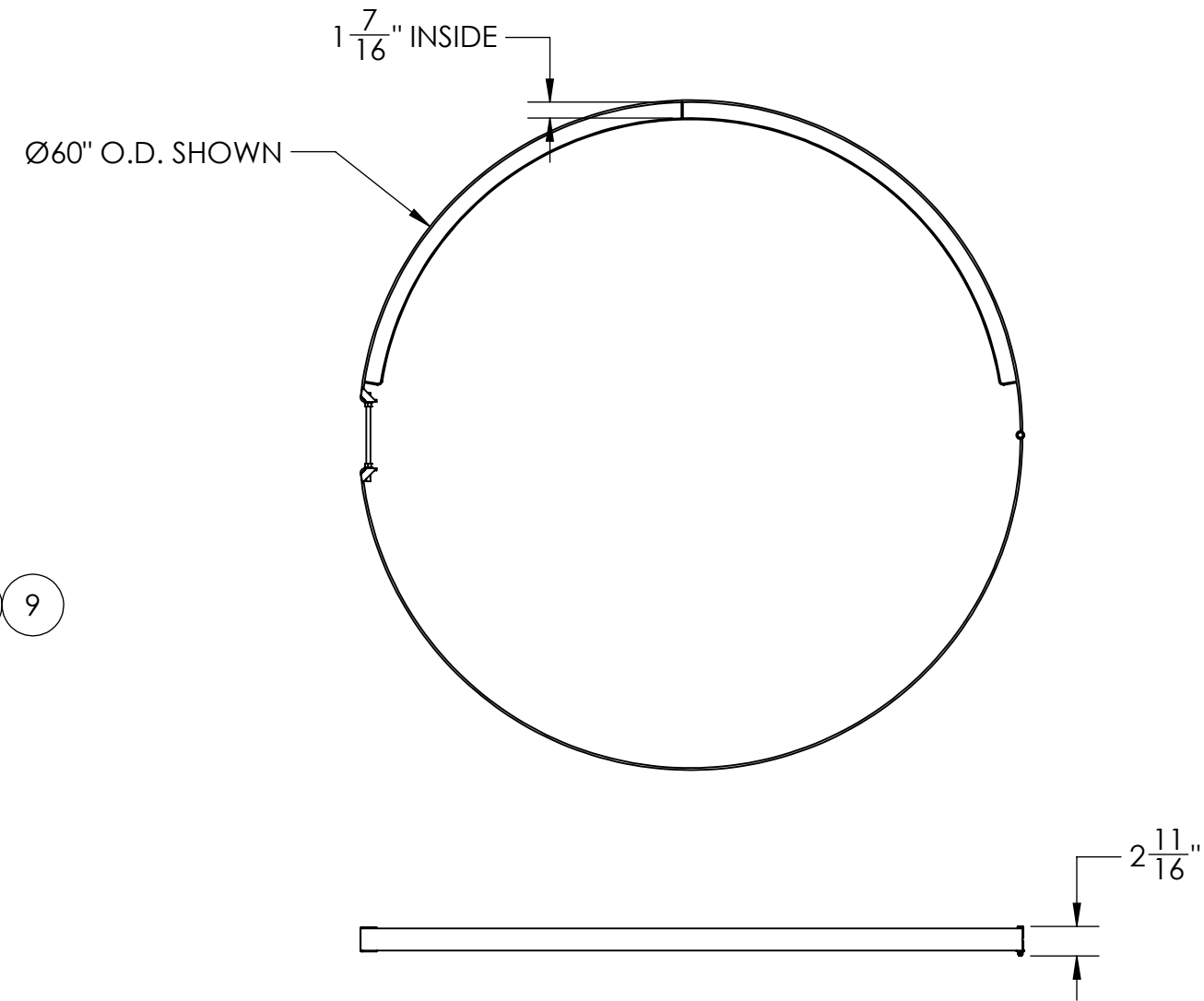
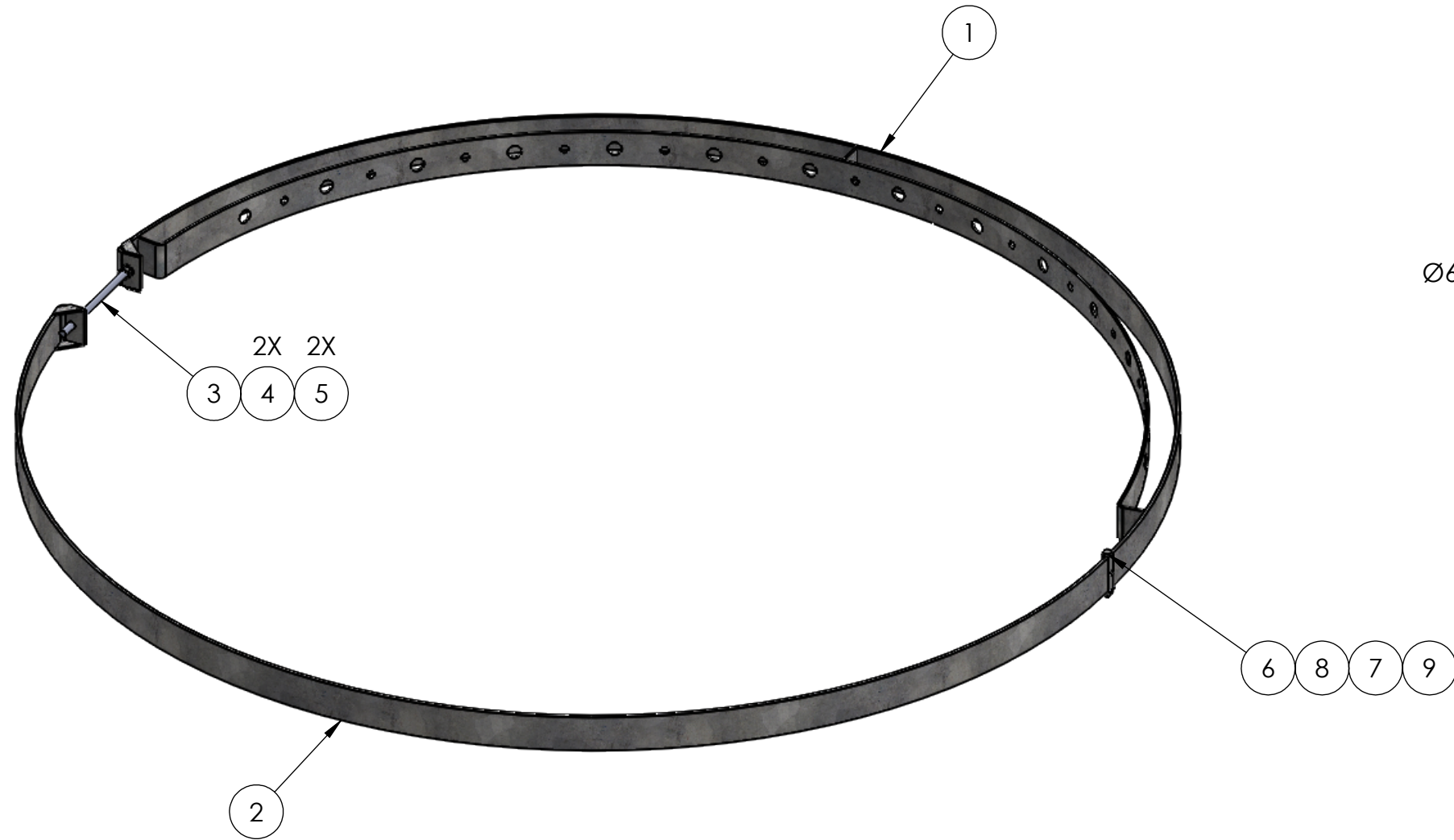

UNLESS OTHERWISE SPECIFIED: DIMENSIONS ARE IN INCHES TOLERANCE $\pm 1/16$		DESCRIPTION: 60" WATER TOWER EXPANSION BRACKET ASSEMBLY	
MATERIAL -		 PRO TOWER MANUFACTURING L.L.C. 5601 San Francisco St. NE Albuquerque, N.M. 87109 (505) 924-2810	DWG NO: WT1328
FINISH H.D.G.			DRAWN BY: AJK CHECKED BY: E. FILMER SHEET: 1 of 1
SIZE B PROPRIETARY AND CONFIDENTIAL THE INFORMATION CONTAINED IN THIS DRAWING IS THE SOLE PROPERTY OF PRO TOWER MANUFACTURING L.L.C. ANY REPRODUCTION IN PART OR AS A WHOLE WITHOUT THE WRITTEN PERMISSION OF PRO TOWER MANUFACTURING L.L.C. IS PROHIBITED.		REV WEIGHT: 25.91	