

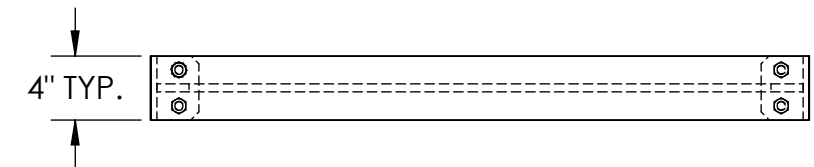

ITEM NO.	PART NUMBER	DESCRIPTION	FINISH	WEIGHT (PER)	QTY.
1	WT1422.01	HALF STIFFENER RING (WELDMENT)	H.D.G.	44.84	2
2	GR500.006	1/2" x 6" THREADED ROD	H.D.G.	0.33	4
3	GN04A	1/2" HEX NUT (2H)	H.D.G.	0.06	8

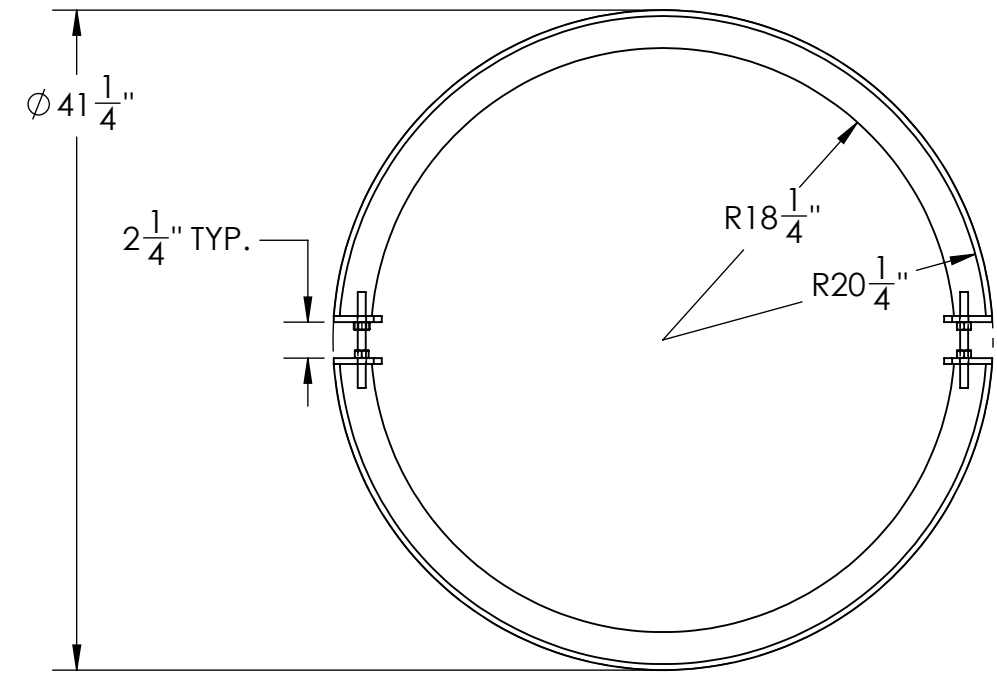
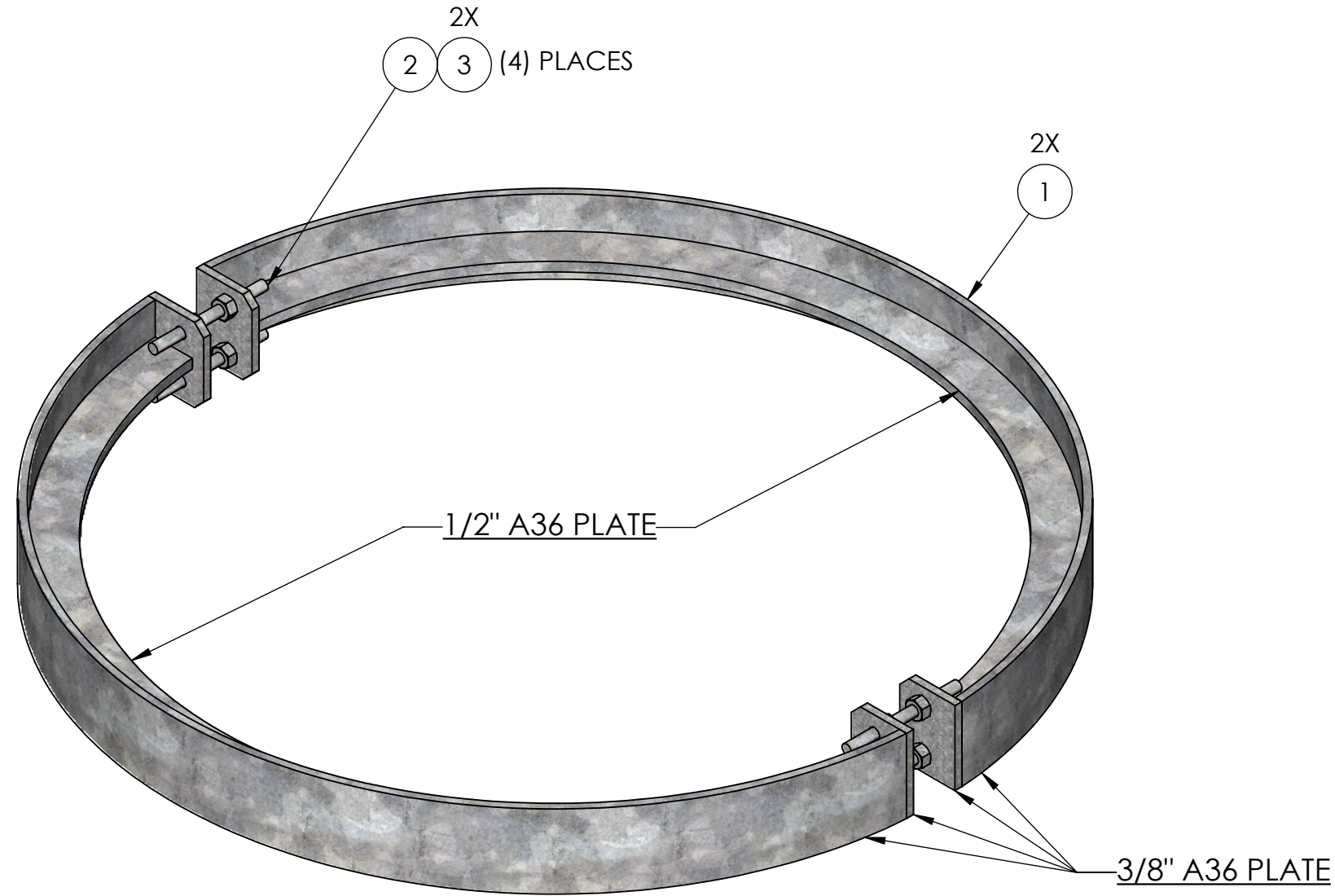

UNLESS OTHERWISE SPECIFIED: DIMENSIONS ARE IN INCHES TOLERANCE $\pm 1/16$		DESCRIPTION: 42" ACCESS TUBE STIFFENER RING KIT		
MATERIAL -		 PRO TOWER MANUFACTURING L.L.C. 5601 San Francisco St. NE Albuquerque, N.M. 87109 (505) 924-2810	DWG NO: WT1422	
FINISH H.D.G.			DRAWN BY: AJK CHECKED BY: E.FILMER SHEET: 1 of 1	DATE: 8/30/2022 DATE: 8/30/2022 SCALE: NTS
SIZE B		PROPRIETARY AND CONFIDENTIAL THE INFORMATION CONTAINED IN THIS DRAWING IS THE SOLE PROPERTY OF PRO TOWER MANUFACTURING L.L.C. ANY REPRODUCTION IN PART OR AS A WHOLE WITHOUT THE WRITTEN PERMISSION OF PRO TOWER MANUFACTURING L.L.C. IS PROHIBITED.		
		REV WEIGHT: 91.54		