

ITEM NO.	PART NUMBER	DESCRIPTION	FINISH	WEIGHT (PER)	QTY.
1	TW1285.01	36" STAND-OFF MOUNT, 2-3/8" x 50" VERT. MAST (WELDMENT)	H.D.G.	42.38	1
2	TW1285.02	STAND-OFF UPPER BENT MOUNTING PLATE (WELDMENT)	H.D.G.	12.79	1
3	TW1285.03	STAND-OFF LOWER BENT MOUNTING PLATE (WELDMENT)	H.D.G.	12.79	1
4	TW1285.04	FLAT BAR BACKING PLATE (1/2" PLATE)	H.D.G.	6.54	2
5	GP2375.126	2-3/8" O.D. x 126" PLAIN END GALV PIPE	H.D.G.	38.49	1
6	GB0622A	3/4" x 2-1/4" HEX BOLT	H.D.G.	0.45	2
7	GN06A	3/4" HEX NUT (2H)	H.D.G.	0.18	2
8	GL06	3/4" LOCK WASHER	H.D.G.	0.05	2
9	GR500.008	1/2" x 8" THREADED ROD	H.D.G.	0.45	8
10	GL04	1/2" LOCK WASHER	H.D.G.	0.02	32
11	GN04A	1/2" HEX NUT (2H)	H.D.G.	0.06	32
12	GF04	1/2" FLAT WASHER	H.D.G.	0.04	24
13	TW1315.01	CROSS OVER CLAMP BRACKET, SM TO SM (WELDMENT)	H.D.G.	2.46	2
14	TW1320.01	CLAMP HALF 1-1/2" TO 3-1/2" OD ROUND (1/2" PLATE)	H.D.G.	1.20	4
15	GR500.006	1/2" X 6" THREADED ROD	H.D.G.	0.33	8

NOTES:
 1. USE HOLE A IN UPPER AND LOWER BRACKET FOR STRAIGHT LEGS.
 2. USE HOLE C IN LOWER BRACKET FOR 2' IN 20' TAPER LEGS. = 3.304 DEG. APEX LEG SLOPE.
 3. USE HOLE B IN UPPER BRACKET AND HOLE C IN LOWER BRACKET FOR 6' IN 20' TAPER LEGS. = .827 DEG. APEX LEG.

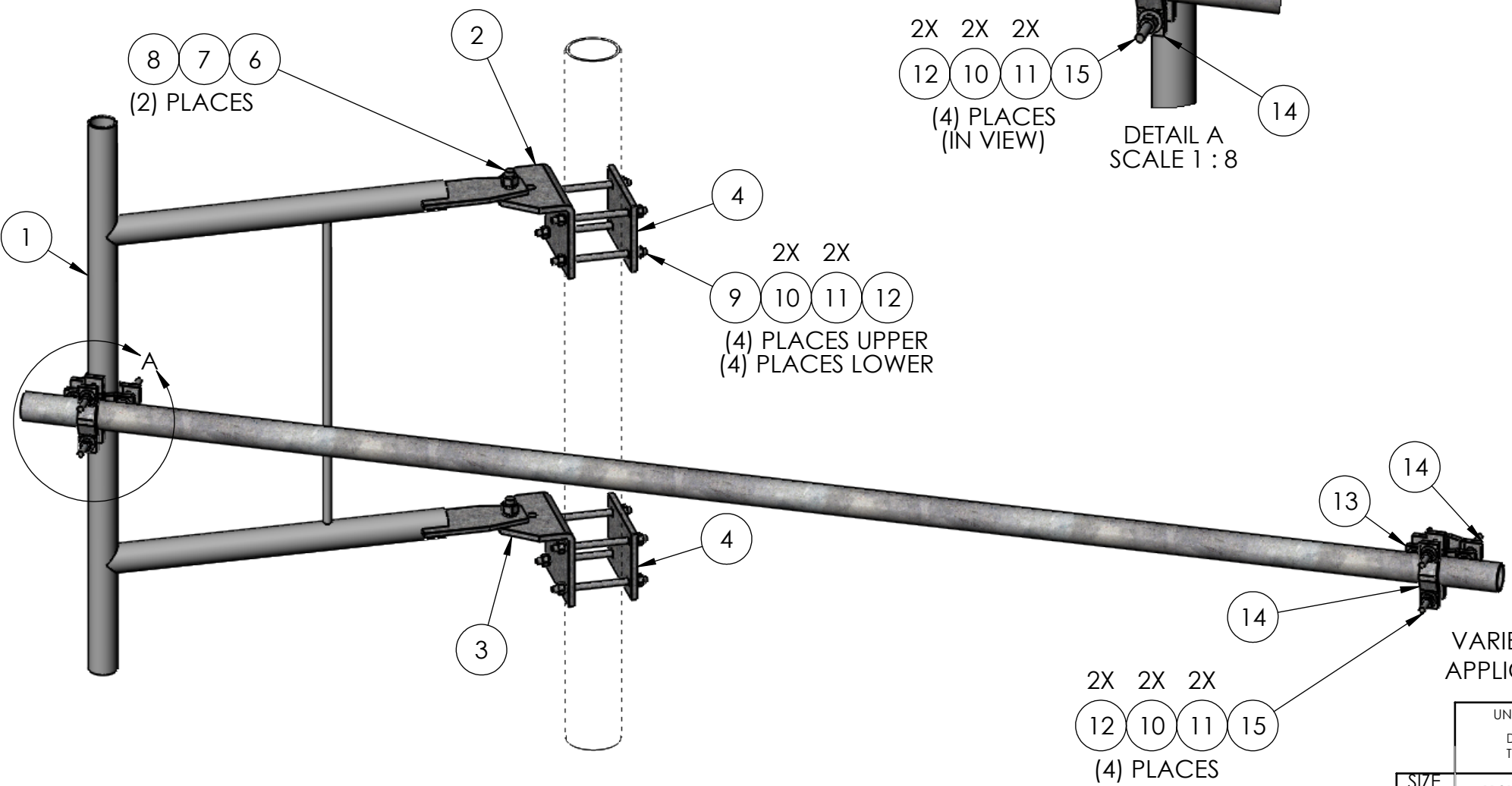

P/N: TW1285-LLAK
 FOR LARGE TOWER
 LEGS (ANGLE & ROUND)
 (ORDER SEPARATELY)

FITS:
 -1-1/2" TO 10-3/4" O.D. ROUND
 -L3" TO L8" ANGLE

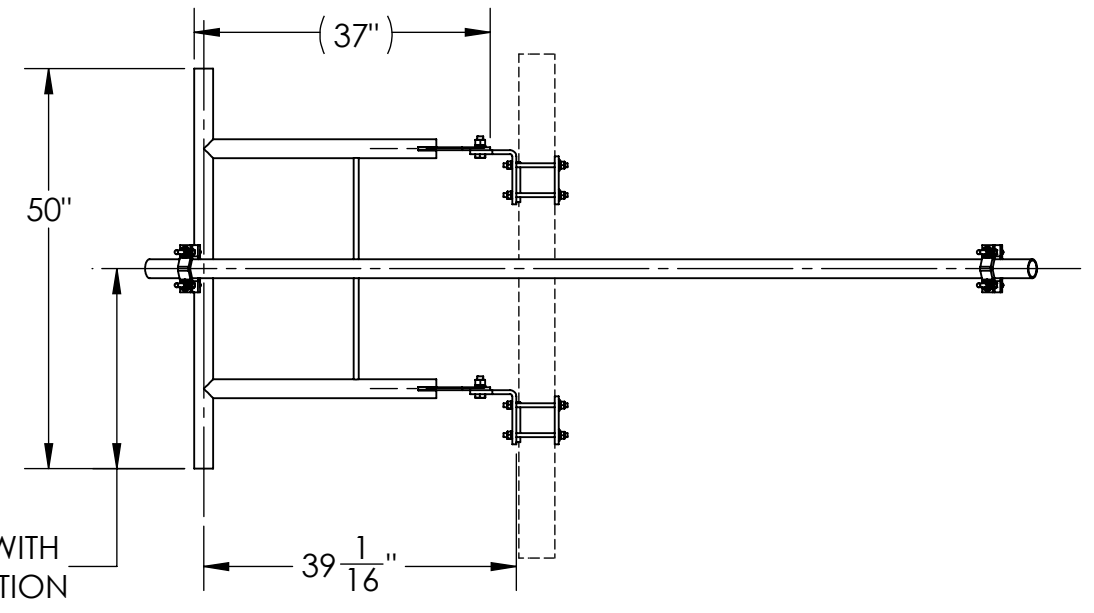

UNLESS OTHERWISE SPECIFIED: DIMENSIONS ARE IN INCHES TOLERANCE ± 1/16		DESCRIPTION: 36" STAND-OFF MOUNT ASSEMBLY, INCLUDES STIFF ARM	
MATERIAL: -		DWG NO: TW1285	
FINISH: H.D.G.		DRAWN BY: AJK	
SIZE: B		DATE: 8/25/2022	
PROPRIETARY AND CONFIDENTIAL THE INFORMATION CONTAINED IN THIS DRAWING IS THE SOLE PROPERTY OF PRO TOWER MANUFACTURING L.L.C. ANY REPRODUCTION IN PART OR AS A WHOLE WITHOUT THE WRITTEN PERMISSION OF PRO TOWER MANUFACTURING L.L.C. IS PROHIBITED.		CHECKED BY: E.FILMER	
		DATE: 8/25/2022	
		SCALE: NTS	
		SHEET: 1 of 1	
		REV: -	
		WEIGHT: 140.37	

PRO TOWER MANUFACTURING L.L.C.
 5601 San Francisco St. NE
 Albuquerque, N.M. 87109
 (505) 924-2810