

ITEM NO.	PART NUMBER	DESCRIPTION	FINISH	WEIGHT (PER)	QTY.
1	TW1073.03	ADAPTER PLATE (F.B. 12" x 3/8" x 9-1/2")	H.D.G.	9.35	2
2	TW1073.02	3' STAND-OFF FRAME ANGLE (L2-1/2" x 2-1/2" x 1/4" x 46-1/2")	H.D.G.	15.32	8
3	TW1073.01	UNIVERSAL ANGLE TO PIPE MOUNT (WELDMENT)	H.D.G.	5.56	4
4	GP2875.102	2-7/8" O.D. x 102" PLAIN END GALV PIPE	H.D.G.	49.42	2
5	GU43045	1/2" x 4-1/2" x 3" x 2" U-BOLT	H.D.G.	0.64	8
6	GF04	1/2" FLAT WASHER	H.D.G.	0.04	32
7	GL04	1/2" LOCK WASHER	H.D.G.	0.02	58
8	GN04A	1/2" HEX NUT (2H)	H.D.G.	0.06	58
9	GP2375.126	2-3/8" O.D. x 126" PLAIN END GALV PIPE	H.D.G.	38.49	1
10	TW1315.01	CROSS OVER CLAMP BRACKET, SM TO SM (WELDMENT)	H.D.G.	2.42	2
11	TW1320.01	CLAMP HALF 1-1/2" TO 3-1/2" OD ROUND (1/2" PLATE)	H.D.G.	1.20	4
12	GR500.006	1/2" x 6" THREADED ROD	H.D.G.	0.33	8
13	GB0414A	1/2" x 1-1/2" BOLT	H.D.G.	0.15	26
14	GB0830A	1" x 2-3/4" HEX BOLT	H.D.G.	1.01	2
15	GL08	1" LOCK WASHER	H.D.G.	0.10	2
16	GN08A	1" HEX NUT (2H)	H.D.G.	0.39	2

UNIVERSAL SADDLE MOUNT KIT SOLD SEPARATELY			
PART NUMBER	DESCRIPTION	FITS (ANGLE & PIPE TOWER LEGS)	QTY.
TW1126	UNIVERSAL SADDLE MOUNT	L2-3/4" TO L4-1/2" / Ø1-3/4" TO Ø6-5/8" O.D.	1
TW1128	UNIVERSAL SADDLE MOUNT (LONG LEG ADAPTER KIT)	L3" TO L8-1/2" / Ø1-3/4" TO Ø12" O.D.	1

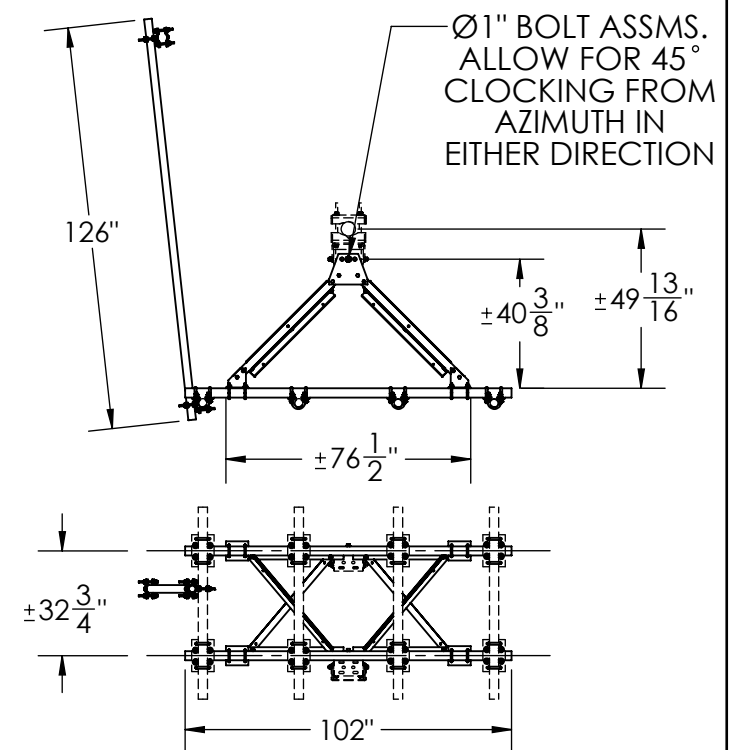

FITS ANGLE & ROUND TOWER LEGS (SEE OPTION TABLE)

STANDARD & LONG LEG UNIVERSAL SADDLE MOUNT KITS SOLD SEPARATELY (SEE OPTION TABLE)

ANTENNA PIPE MOUNT KIT (SOLD SEPARATELY)

REVISIONS			
REV.	DESCRIPTION	DATE	APPROVED
A	INCREASED SIZE FROM 2" SCH40 TO 2-1/2" SCH40	8/23/2019	E. FILMER

MATERIAL -	FINISH H.D.G.	UNLESS OTHERWISE SPECIFIED: DIMENSIONS ARE IN INCHES TOLERANCE ± 1/16	DESCRIPTION: 8'-6" HD V-SECTOR FRAME, 3' STAND-OFF, ANTENNA PIPE NOT INCLUDED	DWG NO: TW1073.102	
				PRO TOWER MANUFACTURING L.L.C. 5601 San Francisco St. NE Albuquerque, N.M. 87109 (505) 924-2810	DRAWN BY: AJK CHECKED BY: E. FILMER SHEET: 1 of 1
PROPRIETARY AND CONFIDENTIAL THE INFORMATION CONTAINED IN THIS DRAWING IS THE SOLE PROPERTY OF PRO TOWER MANUFACTURING L.L.C. ANY REPRODUCTION IN PART OR AS A WHOLE WITHOUT THE WRITTEN PERMISSION OF PRO TOWER MANUFACTURING L.L.C. IS PROHIBITED.			DATE: 9/13/2022 DATE: 9/13/2022 SCALE: NTS	REV A WEIGHT: 326.25	