

ITEM NO.	PART NUMBER	DESCRIPTION	FINISH	WEIGHT (PER)	QTY.
1	RT1200.01	TRIPOD FOOT WELDMENT	H.D.G.	4.71	3
2	RT1200.02	TRIPOD STRUT (L3" x 3" x 1/4" x 48")	H.D.G.	19.53	6
3	RT1200.03	TRIPOD SUPPORT (F.B. 1/2" x 2" x 24")	H.D.G.	6.72	3
4	RT1203.01	3-1/2" TRIPOD CLAMP	H.D.G.	2.96	6
5	GB0524A	5/8" x 2-1/4" HEX BOLT	H.D.G.	0.31	12
6	GL05	5/8" LOCK WASHER	H.D.G.	0.03	12
7	GN05A	5/8" HEX NUT(2H)	H.D.G.	0.12	12

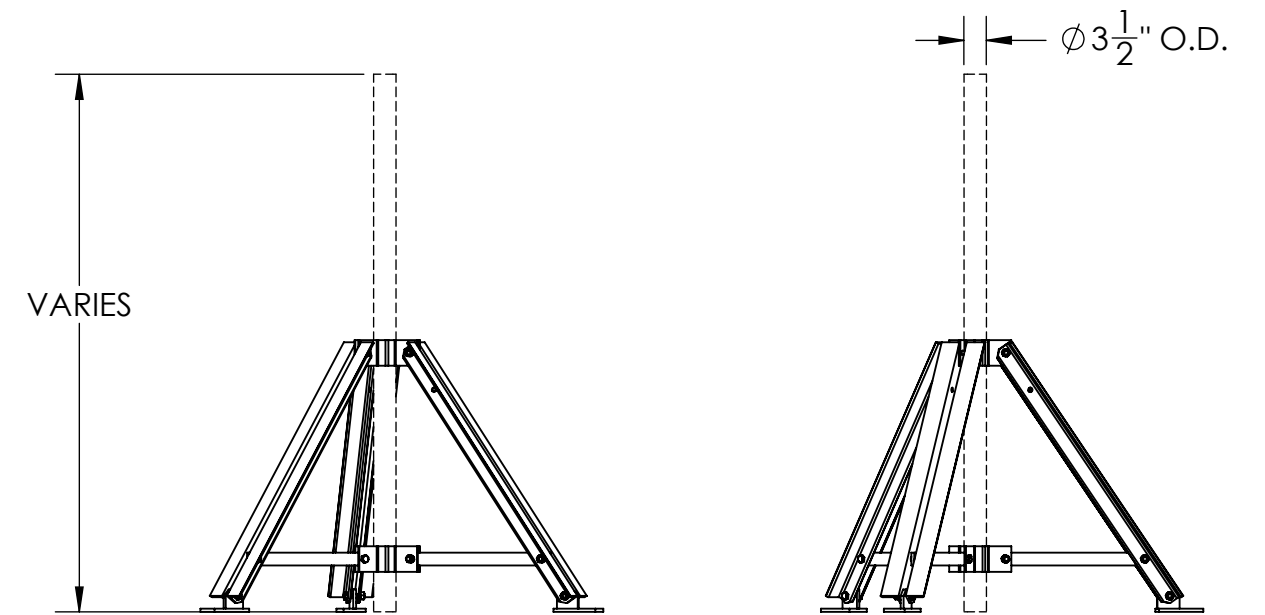
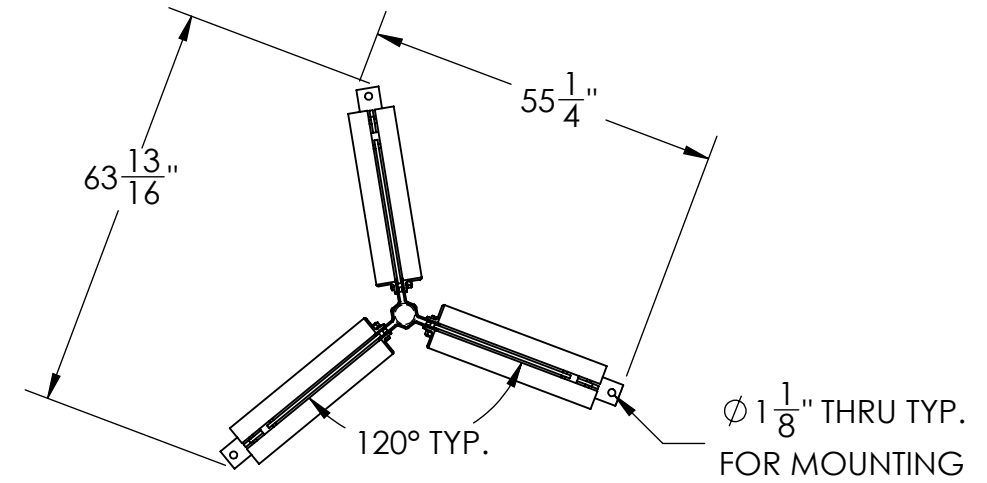
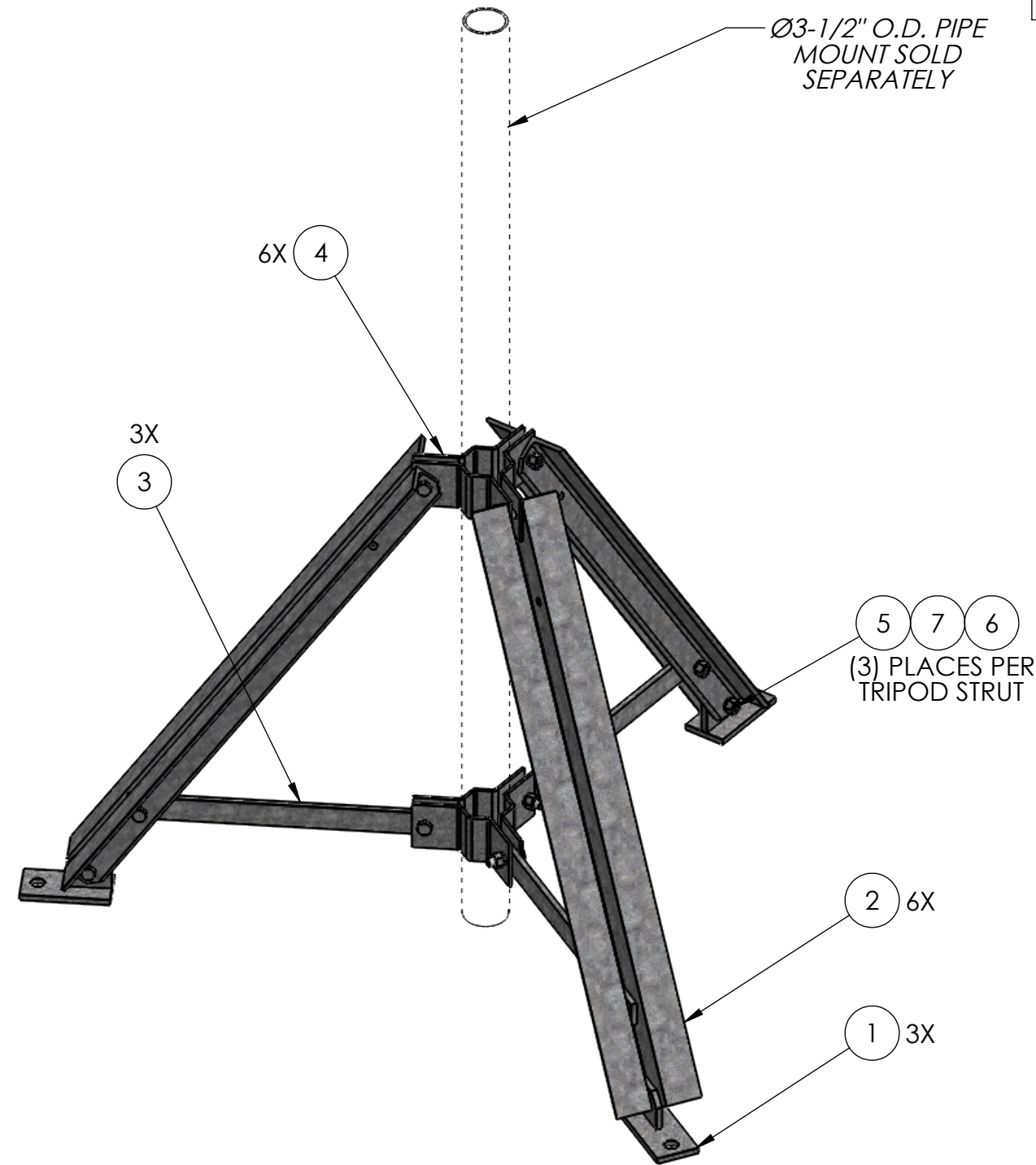

UNLESS OTHERWISE SPECIFIED: DIMENSIONS ARE IN INCHES TOLERANCE ± 1/16		DESCRIPTION: 3-1/2" TRIPOD MOUNT, NO PIPE	
MATERIAL -		 PRO TOWER MANUFACTURING L.L.C. 5601 San Francisco St. NE Albuquerque, N.M. 87109 (505) 924-2810	DWG NO: RT1203
FINISH H.D.G.	SIZE B		DRAWN BY: A.J.K. CHECKED BY: T.SMYTHE SHEET: 1 of 1
PROPRIETARY AND CONFIDENTIAL THE INFORMATION CONTAINED IN THIS DRAWING IS THE SOLE PROPERTY OF PRO TOWER MANUFACTURING L.L.C. ANY REPRODUCTION IN PART OR AS A WHOLE WITHOUT THE WRITTEN PERMISSION OF PRO TOWER MANUFACTURING L.L.C. IS PROHIBITED.		DATE: 7/6/2021	REV
		DATE: 7/6/2021	WEIGHT: 174.75
		SCALE: NTS	