

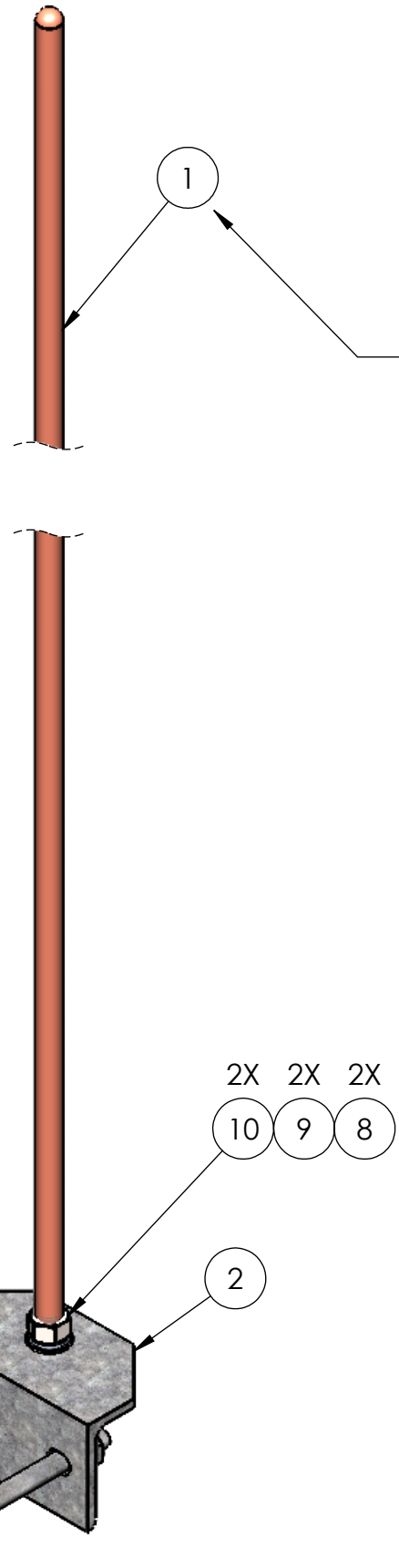

ITEM NO.	PART NUMBER	DESCRIPTION	FINISH	WEIGHT (PER)	QTY.
1	-	(SELECT STEEL-COPPER COATED 5/8" ROD FROM ABOVE)	-	-	1
2	GA3.250	L3" x 3" x 1/4" x 6"	H.D.G.	2.22	1
3	TW1320.01	CLAMP HALF 1-1/2" TO 3-1/2" OD ROUND (1/2" PLATE)	H.D.G.	1.20	1
4	GR500.006	1/2" x 6" THREADED ROD	H.D.G.	0.33	2
5	GF04	1/2" FLAT WASHER	H.D.G.	0.04	4
6	GL04	1/2" LOCK WASHER	H.D.G.	0.02	4
7	GN04A	1/2" HEX NUT (2H)	H.D.G.	0.06	4
8	SF056	9/16" FLAT WASHER	STAINLESS	0.01	2
9	SL056	9/16" LOCK WASHER	STAINLESS	0.02	2
10	SN056	9/16" HEX NUT	STAINLESS	0.06	2

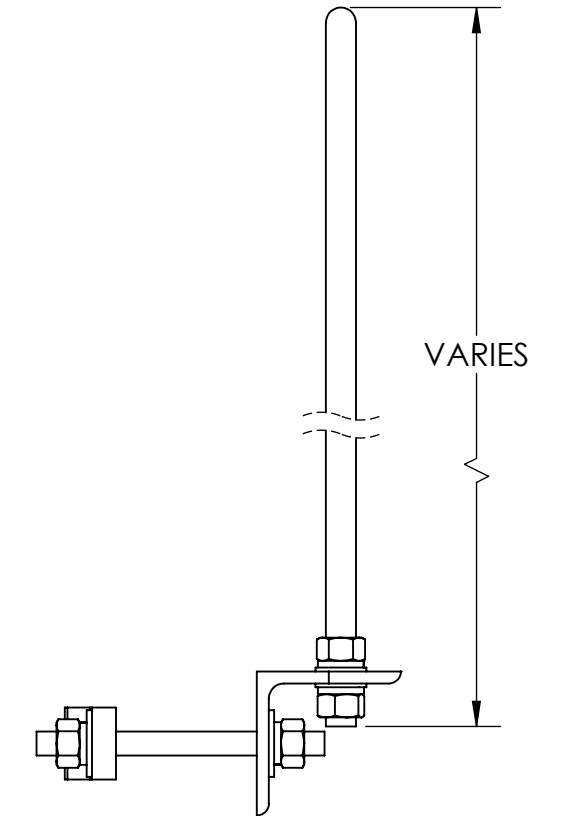
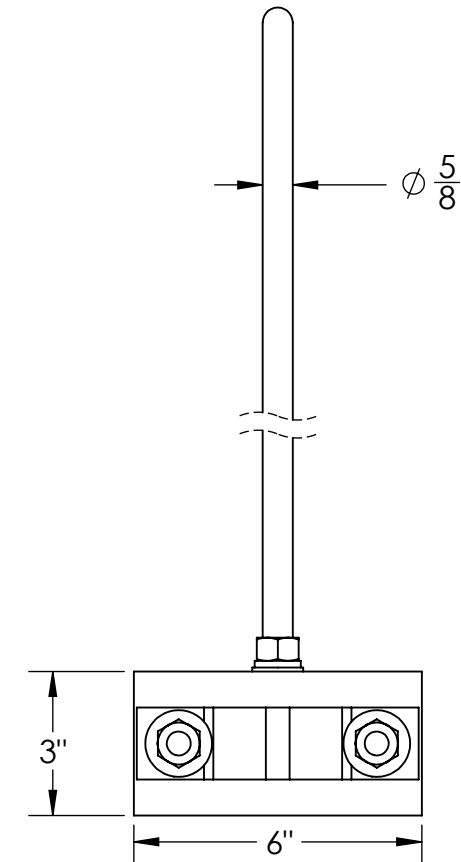
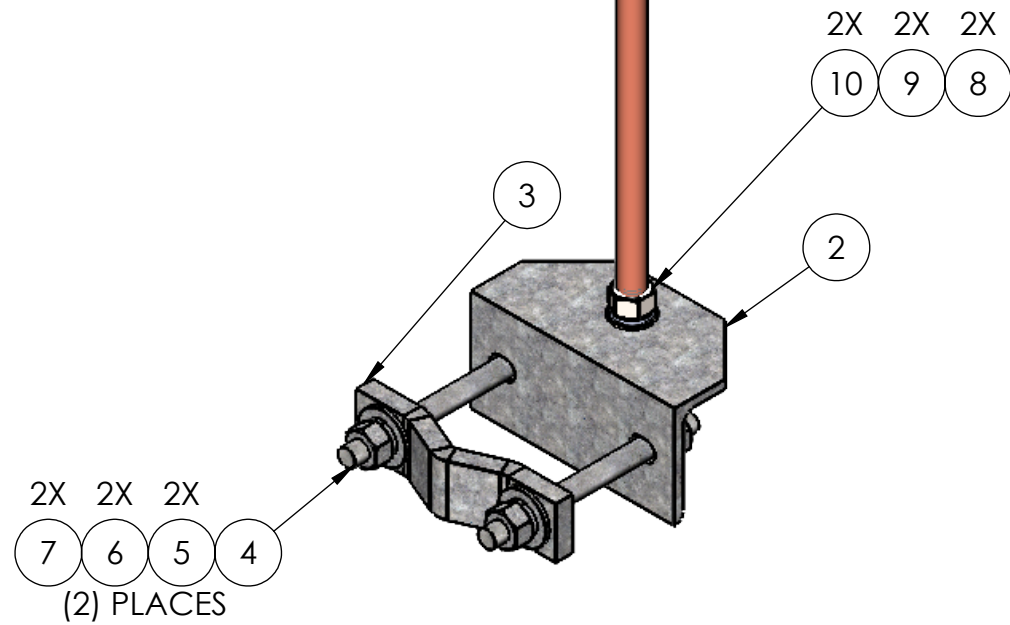

SELECT LIGHTNING ROD KIT LENGTH FROM OPTION TABLE

LIGHTNING ROD KIT (OPTION TABLE)					
ITEM NO.	PART NUMBER	DESCRIPTION	FINISH	WEIGHT (PER)	QTY.
-	LRK03	STEEL-COPPER COATED 5/8" x 3FT	H.D.G.	7.24	1
-	LRK05	STEEL-COPPER COATED 5/8" x 5FT	H.D.G.	10.65	1
-	LRK08	STEEL-COPPER COATED 5/8" x 8FT	H.D.G.	13.15	1
-	LRK10	STEEL-COPPER COATED 5/8" x 10FT	H.D.G.	16.56	1



UNLESS OTHERWISE SPECIFIED: DIMENSIONS ARE IN INCHES TOLERANCE $\pm 1/16$		DESCRIPTION: LIGHTNING ROD ASSEMBLY KIT	
MATERIAL: -	FINISH: H.D.G.	 PRO TOWER MANUFACTURING L.L.C. 5601 San Francisco St. NE Albuquerque, N.M. 87109 (505) 924-2810	DWG NO: LRK SERIES
SIZE: B	PROPRIETARY AND CONFIDENTIAL THE INFORMATION CONTAINED IN THIS DRAWING IS THE SOLE PROPERTY OF PRO TOWER MANUFACTURING L.L.C. ANY REPRODUCTION IN PART OR AS A WHOLE WITHOUT THE WRITTEN PERMISSION OF PRO TOWER MANUFACTURING L.L.C. IS PROHIBITED.		DRAWN BY: AJK CHECKED BY: E. FILMER SHEET: 1 of 1
		REV: - WEIGHT: -	